

Themes for Christian Studies Level 5 Age 9

Contents

God is Creator	5	God is Pure	57
God is Love	13	God is Patient	63
God is Wise	27	God is a Servant	71
God is Protector	33	God is Life	79
God is Powerful	42	God is Provider	85
God is Truth	50	God is Peace	92

Related resources

Songs from the following Beacon Media recordings:

All Creation Sings

Sing a Joyful Song

Couldn't Be Finer

Jesus First - a guide to character development (*Beacon Media*)

© Cheryl Reid
Beacon Media, Australia
Cheryl@beaconmedia.com.au

Themes Level 5 (age 9)

Biblical Overview

God is Creator

God created us with the ability to choose

The creation and fall (Gen. 1-3)

Adam chooses names for the animals (Gen. 2:19-20)

Cain and Abel (Gen. 4)

Joshua asks the Israelites to choose which god they will serve (Jos. 24)

Moses chose to obey (Ex. 3-4)

God is Love

God wants us to love others

The good Samaritan (Luke 10:25-38)

God treats everyone on the same basis (Acts 10:34)

Love is patient and kind (1 Cor. 13:14)

Warning against prejudice (James 2:1-9)

God wants us to love the poor (Matt. 25:35-36)

Ruth's faithfulness to Naomi (Ruth)

The woman at the well (John 4:1-30)

Jesus, friend of publicans and sinners (Matt. 9:10-12; Luke 5:30)

God is Wise

It is wise to be prepared

The wisdom of the ant (Prov. 6:6)

Warning against laziness (Prov. 19:5)

Wisdom is storing up heavenly treasure (Matt. 6:19-21)

The wise and foolish builders (Matt. 7:24-28)

The ten girls and their lamps (Matt. 25:1-13)

God is Protector

God protects us from harm and evil

Angels protect us (Ps. 91)

The Lord is my Shepherd (Ps. 23)

The armour of God (Eph. 6:10-18)

Elisha and God's army of angels (2 Kings 6)

Fear not (Is. 41:10 & 43:1-2)

Three men in the fiery furnace (Daniel 3)

An angel saves Peter (Acts 12:1-9)

God is Powerful

God has power to change things

Jesus changed the lives of the first disciples (John 1:35-50; Matt. 4:18-21; Matt 9:9-13)

Zacchaeus (Luke 19:9-13)

Healing for a paralysed man (Matt. 9:1-8)

Saul's conversion (Acts 9)

Healing for Naaman (2 Kings 5)

Jesus changed water to wine (John 2:1-12)

Nothing too difficult for God (Jer. 32:17)

God is Truth

True or false?

Jesus tempted by Satan (Matt. 4:1-11)

Satan, an angel of light (2 Cor. 11:14)

Father of lies (John 8:44)

Don't believe every spirit (1 John 4:1)

Satan is deceitful (Eph. 6:11; Gen. 3:1)

Resist the devil (James 4:7)

The Holy Spirit guides us into all truth (John 16:13; 1 John 5:6; John 14:15-21)

Speak truthfully about others (Eph. 4:25-32)

Think about things that are true (Phil 4:8)

God is Pure

Christians should be lights to the world

Live as children of the light (Eph. 5:8-11)

Christians as salt and light (Matt. 5:13-16)

Jesus, the light of the world (John 8:12)

Walk in the light (1 John 1:5-7)

The armour of light (Rom. 13:12)

Goodness, a fruit of the Spirit (Gal. 5:22; Deut. 6:18)

Things that are true, noble, right and pure (Phil. 4:8-9)

God is Patient

The Holy Spirit produces patience and self-control

The fruit of the Spirit (Gal. 5:22)

Control of anger (James 1:9; Prov. 19:11; Ecc. 7:9; Eph. 4:26)

Peter acted in anger (Luke 22:47-51)

Love your enemies (Matt. 5:44)

The patience of Job (Job)

King Saul's uncontrolled anger (1 Sam. 17; 1 Sam 26)

Control of greed (Heb. 13:5)

God is a Servant

Jesus, the faithful servant

Jesus was faithful to the disciples (John 17:1-26)

Jesus loved and forgave His friends (Luke 10:4; Matt. 17:27; John 21:15)

Jesus washed the disciples' feet (John 13:4-5)

The faithful servant (Luke 12:35-47)

Faithful friendship between David and Jonathan (1 Sam. 18-20)

A friend loves at all times (Prov. 17:17)

Faithfulness of the disciples and apostles (Acts 1-2; Acts 4:13-22; Acts 7)

Faithfulness in little things (Luke 16:10)

Parable of the talents (Matt. 25:14-29)

God is Life

God is the joy of life

Joyful praise to the Lord (Ps. 95:1-5; Ps. 100; Ps. 147:1 & 7; Ps. 66:1; Ps. 148; Ps. 149; Ps. 150)

The people praised Jesus as He entered Jerusalem (Luke 19:37-40)

Joy is a fruit of the Spirit (Gal. 5:22)

The lame man healed (Acts 3:1-10)

Paul and Silas sang praises in jail (Acts 16:23-26)

Rejoice in the Lord (Phil. 4:4)

God is Provider

God is a faithful provider

Bitter water made sweet in the desert (Ex. 15:22-27)

Manna and quails (Ex. 16)

Water from a rock (Ex. 17)

God is to be trusted (Ps. 56:3; Ps. 20:7; Ps. 119:86)

God is Peace

Trouble outside, peace inside

The house on the rock (Matt. 7:24-26)

Job's trust in God (Job)

Inner peace and comfort of the Holy Spirit (John 14:1-3,18,25-27)

Comfort in times of trouble (2 Cor. 1:3-4; John 16:33)

Jesus calmed the storm (Mark 4:35-41)

Daniel's trust in God (Daniel)

David's trust in God (1 Sam 17)

Peace is a fruit of the Spirit (Gal. 5:22)

Other Stories

Adam Names the Animals (*Creator 5.1*)

Modern-day Good Samaritan (*Love 5.1*)

Nabor, the Aboriginal (*Love 5.1*)

Who do we Love? (*Love 5.2*)

Caroline Chisholm (*Love 5.2*)

Seeing Through the Eyes of Christ (*Love 5.4*)

The Ant and the Grasshopper (*Wise 5.1*)

Be Prepared (*Wise 5.2*)

Tomorrow You Die (*Protector 5.3*)

Galileo Searches for Truth (*Truth 5.2*)

Mr. Biggs (*Pure 5.1*)

The Greedy Dog (*Patient 5.2*)

The Golden Eggs (*Patient 5.2*)

Gladys Aylward (*Provider 5.1*)

The Two Artists (*Peace 5.1*)

Houdini (*Peace 5.2*)

Blonden, the Tight-rope Walker (*Peace 5.2*)

God is Creator

Level 5 (age 9)

Subtheme

God created us with the ability to choose

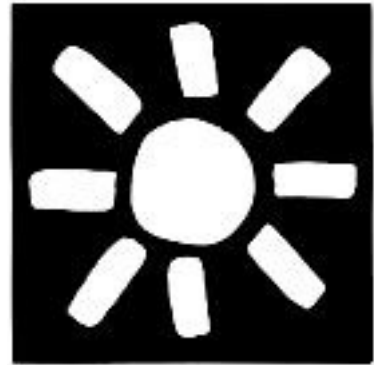

You created the moon to mark the months; the sun knows the time to set. Psalm 104:19 (GNB)

Integrated topics for Christian Education

Animal life; human responsibility towards animals

Other

light
plants
animal life; ecosystems
human biology; self concept
solar system
air
water
fossil records; the Flood; the six-day creation
technology; inventions

Character development *(see Jesus First)*

confidence
creativity
flexibility
resourcefulness

Christian Life

Our response to *God is Creator*

standing in awe of the Creator
praising Him for His great works
believing in a six day creation, (not millions of years).

God is Creator 5.1

Subtheme

Created to choose

Focus

God created people with special gifts and abilities, including the ability to make choices and decisions.

Bible references

Genesis 1 The six days of creation.

Genesis 1:26-30 God created human beings in His image. He placed them above other created things.

Genesis 2 The creation of human beings; God's instructions about the tree of Good and Evil.

Genesis 2:19-20 God gave Adam the responsible task of naming the animals.

Songs

All Creation Sings (*All Creation Sings*)

Sing a Joyful Song (*Sing A Joyful Song*)

God Loves You (*All Creation Sings*)

Couldn't Be Finer (*Couldn't Be Finer*)

Story 1: The seven days of Creation.

Read or tell the story from Genesis 1.

Discussion

Revise the sequence of events in the seven days of Creation.

On the sixth day God created land animals and man.

Why was man special? (Read Genesis 1:26-30)

God said that He would make man in His image. Just as God can think, choose, decide and create, so can we. By placing people in charge of the plants and animals, God was giving them an opportunity to make choices and decisions. One of Adam's first jobs was to choose names for all the animals. Read about this in Genesis 2:19-20.

Story 2: Adam names the animals

The children sat around the campfire on a clear starry night. They loved to go camping with Grandpa. They especially loved these times when they were allowed to stay up a little later than usual. They would cook food over the fire. Then Grandpa would tell a story.

"Twit-twoo," they heard from the bush.

"That's an owl," said Grandpa. "Listen carefully and you might hear some other night animals. The bush is very active at night you know. Many animals are awake at night time."

The children all listened carefully.

"There's a sound," whispered one.

"That's a morepork owl," whispered Grandpa. "He gets his name from the noise he makes. Listen."

"How did the animals get their names anyway?" asked Hannah.

"Well," said Grandpa. "I'll tell you the story. It's a very old story actually. It's as old as the Creation itself."

"After God made the world," went on Grandpa, "He made a man called Adam. One of the first things God asked Adam to do was to give names to all the animals...not just the land animals but the birds and fish as well. God did this because He wanted Adam to know that animals were created to help humans. Some animals were tame and some were wild, but whether tame or wild, Adam was to take care of them. God wanted Adam to name the animals so that he would get to know them, and also, so that he would realise his responsibility in taking care of them.

It must have been fun for Adam to think up names for the animals. Just imagine. 'That one with the long neck... I'll call him a giraffe... and what could I call that funny animal that looks a bit like a duck and a bit like a beaver. I'll have to call him a platypus... and that friendly one...I think he would like to be my special friend. I'll call him a dog.'

Adam spent a long time naming the animals. He remembered what God had told him: "You shall rule over all the animals of the earth."

Adam knew what God meant. He was to look after all the animals. He was to be God's caretaker. What a responsible job that was. Adam felt happy that God had given him the ability to make choices and decisions.

Discussion

God created the animals so that we could enjoy them. Some animals provide for us. Some animals are just good friends. God wants us to take care of all the animals in His creation.

1. We should remember that when God first created the animals, there was no killing, because sin had not yet entered the world. Adam, Eve and all the animals ate only plants. Write the bible verses that tell us this. (Genesis 1:29-30).
2. Read the verses that tell us that Adam named the animals, (Genesis 2:19-20). Write the part that tells us that Adam named the animals.
3. How does the morepork owl get its name?
4. Make a list of some of the choices and decisions that Adam had to make, (e.g. He could choose right from wrong; to obey or disobey God.)
5. What did God mean when He said that people would rule over the animals?
6. Give some examples of ways in which people can take care of God's creation, including animals.
7. Name two animals that are endangered today, and explain why they are endangered.

Art/Craft

Make or draw some flying creatures, representing day 5 of the creation: birds, pterandons (flying dinosaurs), butterflies and all kinds of flying insects. Drawings may be cut out and used as part of a group creation mural.

God is Creator 5.2

Subtheme

God created us with the ability to choose.

Focus

A wrong choice

Bible references

Genesis 3 The Fall

Genesis 4 Cain and Abel

Songs

Adam and Eve (*Couldn't Be Finer*)

Whatever is Good (*Couldn't Be Finer*)

Introduction

Ask someone to choose an item of food, a toy or any other article from a page of advertising material, or collection of pictures.

Explain

God could have created Adam and Eve like robots. He could have made them to think and act exactly as HE wanted them to. However, God did not do this. He gave them a mind to think with. He gave them the ability to make decisions for themselves. He gave them a conscience too, so that they would know the difference between right and wrong.

The problem came when Adam and Eve did not listen to their consciences. They knew the right thing to do. They knew that God had forbidden them to eat a certain kind of fruit, but they chose to disobey.

Story 1: Adam and Eve disobey

Read or tell the story from Genesis 3:1-14 and 21-24.

Adam and Eve chose to disobey, and the children born to them disobeyed God as well.

Story 2: Another wrong choice

Adam and Eve had two sons. They called their first son Cain, and the second one, Abel. When the boys grew up they helped their parents to grow food and look after the animals. Cain became a farmer. He grew grain and fruit and vegetables. Abel became a shepherd.

It was the custom in those days to bring an offering once a year to say 'thank you' to God for providing everything they needed. They built a special table called an altar, and placed upon it their gifts to God. Abel brought a lamb, and Cain brought some of the produce that he had grown.

God was happy with Abel's gift because Abel had chosen to love and obey God. God was not happy with Cain's gift because Cain did not love God. Cain chose evil. He knew in his heart that God was not happy with him. He also knew that God was happy with Abel. Cain became angry and jealous. He was jealous of his brother who always chose good.

God is Creator

When God created people, He gave them the ability to think and choose for themselves. He wanted people to be responsible, and to make good choices. One of the first things Adam had to do was to name the animals. He had to choose names for them. The next choice was a bit more difficult. Adam and Eve had to choose between good and evil. That is, between obeying God or disobeying God. I wonder what choice we would have made. Because of one wrong choice, the whole of creation suffered. People made more and more wrong choices. Cain's wrong choice was just one of many more to follow.

In this story, Cain many wrong choices. It seemed that one wrong choice led to another. Firstly, he ignored God's ways. Then he allowed jealousy to grow in his heart. This finally made him kill his brother. The next step was lying to God.

Bible research and Discussion

1. What did God say to Cain? (Gen. 4:6-7)
2. What did Cain do? (verse 8)
3. What did God say to Cain? (verse 9)
4. What was Cain's answer? (verse 9)
5. Was this the truth?
6. Could Cain hide from God? (verse 10-11)
7. What was the punishment? (verse 12)
8. What was Cain's first wrong choice?
9. How did it lead to other wrong choices?
10. What would you say if someone asked you to do something you knew was wrong?
11. Think of some of the choices we have to make in life. Name some good choices. Name some bad ones.

God is Creator 5.3

Subtheme

We were created with the ability to choose.

Focus

Choosing to obey or disobey God.

Bible references

Genesis 3 Adam and Eve

Genesis 4 Cain chooses evil.

Joshua 24 Choose this day whom you will serve.

Exodus 3-4 The choice to obey God was not easy for Moses.

Romans 1:20 God has made His eternal power and divine nature clear, so that we are without excuse. Everyone has a choice.

Romans 8:9-14 Live as God's Spirit tells you to live. (verse 9)

Galatians 6:7-10 A person will reap exactly what he plants... Let us not become tired of doing (choosing) good. (GNB)

Songs

Adam and Eve (*Couldn't Be Finer*)

Whatever is Good (*Couldn't Be Finer*)

Give Me Ears (*Sing A Joyful Song*)

Introduction

We have to make choices and decisions every day. Some choices are easy to make. Others are not so easy.

Do you sometimes find it difficult to choose what to wear?

If you were allowed to choose one thing from a toy catalogue for your birthday, would you find it difficult?

Do you find it difficult to choose what to eat when you go to a restaurant?

There are other sorts of choices too. If a group of children are saying unkind words about someone in the playground, you can choose to join in, or not to join in. If someone in the playground is lonely you can choose to make friends with that person, or to ignore them.

In these sorts of choices we should ask ourselves, "What would Jesus choose?"

When Jesus lived on earth He always obeyed His Heavenly Father. When we ask Jesus to be in charge of our life, He helps us to choose what is right.

Adam and Eve knew the right thing to do but disobeyed. Cain knew right from wrong too, but he also chose to do the opposite to what his conscience told him. Today, people keep on choosing to do wrong things. This is why all people need God's forgiveness.

There were many people in Bible times who did obey God, just as there are many people today who obey God. Moses was one of these people.

Story 1: Moses obeys God's call.

God had a special plan for Moses. Find out about this from Exodus chapters 3 & 4.

What was this plan? (Exodus 3:1-10)

Was it easy to obey God's command? (Exodus 3:11 & Exodus 4:19)

Moses did obey, even though it was very difficult for him. God gave Moses many signs to let him know that the Lord was with him. Because Moses obeyed, God was able to use him to set the Israelites free.

Can you think of times when it may be difficult for us to obey God?

Story 2: Joshua asks the people to choose

Moses continued to be faithful in obeying God. He led God's people to the Promised Land. However, it was Joshua who took the people into the Promised Land. There were enemies that had to be conquered first, and God chose Joshua to lead the Israelite army into battle against the enemies. When the enemies had been conquered God told Joshua that he could rest. Joshua was an old man by this time.

There were twelve Israelite tribes. These were large family groups. Three of the tribes were already settled on the land on the other side of the River Jordan. Nine tribes still needed a place to make their home. God told Joshua to divide the land among the nine tribes. When all the land was divided, Joshua called the tribes together. Now that his work was finished, Joshua had some final instructions for the people. He wanted to remind the people that they must always worship the true God. The Israelites were going to be living in a land where people around them worshipped false gods. Several times before, the Israelites had fallen into the trap of worshipping false gods. Joshua told the Israelites that they must make the choice now. Would they choose to serve the Lord?

Read about this in Joshua 24:14-27.

Think

Adam, Eve, Cain, Moses and the Israelites were all faced with choices. Try to think of some choices that people could be faced with today in every day life.

EXAMPLES: to forgive or not to forgive; to be honest or dishonest.

Activity 1

Puzzle

Vowels a= ① e= ◆ i= ② o=⊙ u=□

Decode these Bible verses:

L②ve ① l②f◆ wh②ch ②s pl◆①s②ng t② G②d.
Ch②②s◆ y②□ th②s d◆y wh②m y②□ w②ll s◆rv◆.

Activity 2

Make a large fruit tree from cardboard. Place nine fruits on the tree.

Read the list of 'Fruits of the Spirit' (Galatians 5:22-23). Label the fruits.

Choosing to do good is called 'goodness'.

What does Galatians 6:7-10 say about goodness?

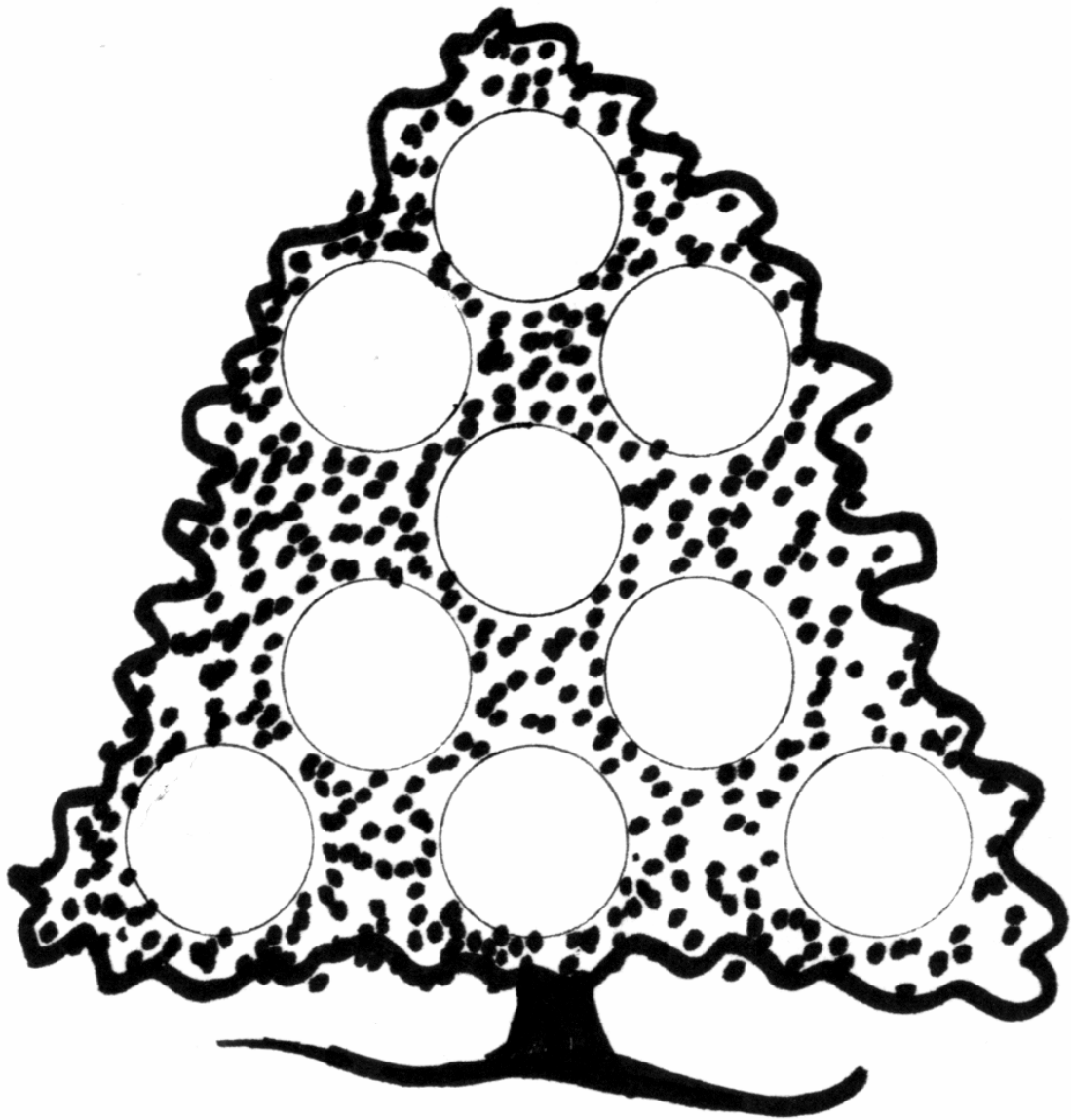

God is Love

Level 5 (age 9)

Subtheme

God wants us to love others.



*The Lord is good. His love is eternal.
Psalm 100:5 (GNB)*

Integrated Topics for Christian Education

Extending love to people of all races and cultures

Other

- myself: God loves me just the way I am
- my family: God's plan for love and protection
- understanding different cultural groups
- understanding the aged and disabled
- professions which show care e.g. nursing
- caring for animals
- God' love for us: provision of the things we need
- the third world: giving and sharing
- friendship, fruits of the spirit
- biographies of those who have shown kindness and compassion
- the balance of nature
- the nation of Israel: Jews and gentiles; God's love for the whole world

Character Development (See *Jesus First*)

kindness
gentleness
friendliness
compassion
forgiveness
faithfulness

Christian Life

Our response to *God is Love*

feeling loved and accepted
loving God as He first loved us
loving others

God is Love 5.1

Subtheme

God wants us to love others.

Focus

God doesn't show favouritism.

Songs

God Loves You (*All Creation Sings*)

Wide Wide as the Ocean (*Sing A Joyful Song*)

Clap Your Hands (*All Creation Sings*)

Down in my Heart (*Couldn't Be Finer*)

Bible references

Luke 10:25-38 The Good Samaritan

1 Corinthians 13:14 Love is patient and kind.

Acts 10:34 God treats everyone on the same basis.

Introduction

Find pictures/photos of different kinds of people.

There are many different types of people in the world. People from different countries have different languages and customs. Some people are young, some are old, some are sick, some are healthy, some are rich, some are poor, some love Jesus, some people don't.

Does God love some of these people more than others?

Bible research

Find out what Acts 10:34 and James 2:1-9 have to say about our attitude towards different kinds of people.

Story 1: The Good Samaritan

Read or tell the story from Luke 10:25-38.

Discussion

Why do you think the first two people refused to help the man by the roadside?

Act it out: Modern day Good Samaritan

Here is a play written by some students from a Christian School in South Australia. Perhaps you could act out the play, or make up your own.

1st Person:

Let's play 'Stuck in the mud'.

2nd Person:

O.K. Good idea.

3rd Person:

I'm definitely not going 'caught'. I went 'caught' first last time.

4th Person:

Alright. Don't complain.

5th Person:

I'll go 'caught'.... ready, go!

(3rd person falls over.)

2nd person:

Ha, ha, ha. That looked so funny.

1st Person:

Let's not bother about him/her.

4th person:

Yeah. Let's not waste OUR lunch time.

5th Person:

Let's go before we have to give a testimony to the teacher.

(6th person comes along.)

6th Person:

You poor thing. Let me help you.

3rd Person:

Oooh.

6th Person:

Looks like you've had a bad accident. There's a great big bump on your head. I'll take you to the first aid room.

(Next day)

3rd Person:

I really don't know why he/she helped me. I've always been nasty to them. Guess I'll go and thank him/her.

Story 2

Nabor the Aboriginal

Many true stories are told about the help that Australian Aborigines have given to white people. The story of Nabor is one of these.

The Australian Aboriginal people did not understand the ways of the first white people, who arrived on the Australian shores over 200 years ago. The Aboriginal people had their own laws which they kept with great care; but the white man's laws were new and strange to them.

When the white people took over the land, many of the past hunting-grounds of the Aboriginal people were lost to them. Since they could no longer hunt for kangaroos and other animals, they, being hungry, took the white man's animals instead.

Sometimes too, they would raid an outback hut, and steal the food. The white people, who needed the food themselves, tried to put a stop to this.

Once, a policeman and his party of 'black trackers' set out to catch four Aboriginal people who had broken the law and raided such a hut. They caught them and fastened them one to the other with chains about their necks. Then the policeman and the trackers, with their captives, set out for home. The captives walked by the police horses.

Now, heavy rains had fallen since the police party had set out, and they found that a small river, which they had crossed before was already in full flood.

On the return, the party had to cross this river. The policeman had told the captives to swim while he and the black trackers went across on their horses. He then undid the chains, and these hung down loosely from their necks. Each of the captives then wound the loose chain about his neck and under his arms.

Then they dived into the water. The captives were all strong swimmers, and all swam the flooded river quite safely. So also did the black trackers. The policeman, however, seemed to have disappeared.

Then they saw that he had been thrown from his horse. He and the horse had both been caught in the strong current. They watched the policeman struggle back to his horse, but the terrified animal kicked him. The policeman fell back into the water unconscious. Already the current was carrying him away. It seemed almost certain that the flood would cost him his life.

Suddenly, Nabor, one of the captives, wound his loose chain about himself and ran along the river bank in the same direction as the current was going. He noted the spot where the policeman was, and running past it, dived into the flooded river. He swam and struggled against the current, until he managed to draw nearer to the policeman.

Even when he reached him the struggle wasn't over. Nabor was tiring, and the chains about him felt heavy. It was hard, in the strong current, to keep the policeman afloat and struggle toward the bank.

The other Aboriginal men had run to the nearest spot, and, as Nabor struggled toward the bank, they took the policeman from his arms and put him carefully on the ground. He lay quite still.

The rest of the party stood and looked down at the one white man among them. He was so pale and still that even then they thought he might die. Then suddenly Nabor wound his loose chain around his arm and disappeared.

He ran straight into the bush; not to escape, but to get help for the white man. For three miles he ran, until he found some white men. With them he hurried back again. These men were able to help the policeman, and soon he looked less pale and began to speak to them. Later he was able to go on his way. When the party reached the police station, the policeman told the story of Nabor's bravery.

This true story was told in the newspapers. When the story reached England, the King decided that Nabor deserved a medal, and ordered that one should be sent to him.

From the Victorian Education Department Reader, Third book. (Author unknown)

Discussion

Do you think the policeman deserved Nabor's act of kindness?

Even though Nabor had probably never read the words of Jesus, he was actually doing as Jesus commands us. Read this in Luke 6:27-28.

Nabor also gave us a true example of what it means to love your neighbour. How is the story similar to the story of the Good Samaritan?

Perhaps Nabor was given his name because of the kindness he showed to all people...even his enemies.

Art/Craft

Make a 'people' collage using magazine pictures. Try to find as many different types of people as possible. Cut them out and paste them on to a large piece of paper. Write a message on the picture about God's love for all people.

God is Love 5.2

Subtheme

God wants us to love others.

Focus

God wants us to love the poor and not to look down on them.

Bible references

James 2:1-9 Warning against prejudice

Acts 10:34 God treats everyone on the same basis.

1 Corinthians 13:14 Love is patient and kind.

Matthew 25:35-36 God wants us to show love to the poor.

Songs

God Loves You (*All Creation Sings*)

Wide Wide as the Ocean (*Sing A Joyful Song*)

Jesus is a Friend (*Sing A Joyful Song*)

Down in my Heart (*Couldn't Be Finer*)

Story 1: Who do we love?

Mr. Lane was a very rich man. He also was a Christian and went to church each Sunday. He always drove his big car and wore a nice suit.

One Sunday morning when he got up he found his paper had not been delivered as usual. He quickly put on his old trousers and jumper and went to the garage. His daughter's small car was blocking his own car, so he got her keys and drove the small car to the newsagent.

Coming back, Mr. Lane got a puncture, so he changed the tyre. He got a bit dirty and it took him much longer than he thought it would. It was nearly time for church. If he went home and changed into his suit he would be late.

He decided to go to church as he was. He brushed the dirt off as best he could and drove the small car into the church yard. To his surprise, as he went into the church, the sidesmen did not greet him warmly as they usually did. He sat in the same seat as usual. A lady he knew came up to him but as he was about to say 'Hello', she said, 'You can't sit there. That's Mr. Lane's seat.' Before he could say 'I am Mr. Lane', she had rushed off.

Mr. Lane was absolutely astonished. People did not seem to recognise him without his suit. As he got into his daughter's car after the service he smiled and waved at a man he knew. The man gave a polite wave but looked at him as if he had never seen him before.

Mr. Lane was quite upset. Were people really interested in him, he wondered, or just his money? How would they treat someone new who was not dressed in a suit?

Mr. Lane thought about it all the following week. He decided to go to another church the following Sunday. This time he again drove his daughter's car, and he deliberately wore old clothes.

Even though the people at this church had never seen him before they were very friendly. Mr. Lane has been going to that church ever since.

Janine Stewart (from 'New Life'; Used by permission)

Discussion/Bible research

1. What was Mr. Lane's own car like?
2. What was his daughter's car like?
3. How did Mr. Lane usually dress for church?
4. How was he dressed on this day?
5. How did people treat him at church on this day?
6. Read James 2:1-8. What warning is given in these verses?
7. Does God love people who are rich more than those who are poor?
8. How does God want us to treat people who are poor?
9. What does it mean to love others as God loves us?

Story 2: Caroline Chisholm

Caroline Chisholm came to Australia in the early 1800s along with many others new settlers. She was married to a sea captain called Archibald. Although originally from Britain, Caroline and Archibald had worked in India, helping British soldiers and their families. They were very excited as they left India to come to a new land. The first European settlers had arrived in Australia only 50 years before.

"Where will we be living, Archibald?" asked Caroline.

"We will be at Sydney, the largest town. My duty will be to help guard the convicts who have been sent out from the over-crowded prisons in England."

When they arrived in Sydney they found it to be a busy, bustling sea-port with narrow, unpaved streets. The horses and carts had churned up the dirt roads so much that they were scarcely useable. Some of the people were rich. They had fine horses and elegant carriages. There were also some wealthy land-owners with well-built homes, but most people had tumble down shacks, or small dingy houses to live in. However, hundreds had no homes at all. They slept under trees or in the shelter of rocks. This is what worried Caroline. She was especially concerned for the young women and girls who had no home.

"Why are there so many young girls on the streets all day and night?" Caroline asked the wife an officer.

"Oh, my dear, the government in England sends out these immigrants. They are expected to find work and a home when they arrive in Sydney, but there's not enough work for all the people who arrive here," was the reply.

Caroline decided that she wanted help the young women. She took as many as she could into her own home, but there were hundreds more sleeping on the streets and in the parks.

"Something must be done!" she said to Archibald. "These girls need a big home where they can be sheltered and protected. I'm going to see if any of our friends can help me do something for them."

At first no one was helpful. Then after a lot of persistence, Caroline finally persuaded the governor to allow her to use an old building for the girls. The walls were cracked and it was rat infested. The only light was from her own candle.

Caroline poisoned the rats and cleaned up the old building as best she could. Soon she had ninety young women to care for. She asked friends to give food to feed the girls. She then tried to find jobs for the girls. Many of the jobs were on farms in the country. The girls, who had come from the crowded cities of England, were too afraid to go to the country on their own, so Caroline went with them. The roads were rough and there were rivers without

bridges to be crossed. The hot sun would beat upon them and the rain poured into the open cart. Bushrangers made the journeys dangerous. These men would often hold up travellers in order to rob them.

As time went on Caroline worked at bringing together again the families of convicts. Many people had been imprisoned for small crimes like stealing a loaf of bread. As punishment, these people had then been sent to Australia to work. They were therefore separated from their families. Caroline arranged for wives and children who had been left behind in England to join their fathers and husbands in the new colony.

Caroline is remembered most of all today for her kindness to needy young women, at a time when their troubles were ignored by everyone else. She loved God and shared His love with others, giving up her own comforts to help those in need.

From Margaret McIntyre's collection (Used by permission)

Discussion

How did Caroline carry out the words of Jesus in Matthew 25:35-36?

What can Christians learn from her example?

Is it possible to help the poor because we think we SHOULD, and not really love them?

Read Galatians 5:22-23. Think about the fruit of kindness.

Caroline Chisholm chose to be kind when others around her couldn't be bothered.

Sometimes we have to make an EFFORT to be kind. It is easy to ignore those who need our kindness when everyone else is ignoring them.

Here is a situation:

Ben is sitting by himself in the playground. He can't join in the game because he has a permanent disability and has to use crutches.

Which is easier...

- To go and join the others... (after all, everyone else is ignoring Ben.)
- To go and spend some time with Ben

Activity

Show the fruit of kindness by being an 'angel' to someone this week. Do not let the person know that you are going to be their angel. Plan ways of showing kindness towards that person, but do your acts of kindness in secret. You can do anonymous jobs for them, or make gifts for them. Write the person's name on the gift and leave it in a place for them to find. You could also make message cards. Write something that would make the person feel happy. It could be a verse from the Bible.

God is Love 5.3

Subtheme

God wants us to love others.

Focus

Just as God is faithful in His love towards us, He wants us to be faithful in our love towards others.

Bible references

Ruth (Ruth was faithful in her love toward Naomi.)

Luke 10:27 Love the Lord with all your heart... and your neighbour as yourself.

Songs

God Loves You (*All Creation Sings*)

Clap Your Hands (*All Creation Sings*)

Wide Wide as the Ocean (*Sing A Joyful Song*)

Jesus is a Friend (*Sing A Joyful Song*)

Down in my Heart (*Couldn't Be Finer*)

Introduction

Review the Fruits of the Spirit: goodness, love, kindness and patience.

Think about another fruit: **faithfulness**.

Faithful love never gives up. That's how God's love is towards us. He never gives up loving us. God wants us to be faithful in our love towards others too.

Story: Ruth and Naomi

Long ago, in Old Testament times, lived a man called Elimelech and his wife Naomi. Their home was in Israel, but during a time of drought, they moved away from Israel to a land where there was more food. The new place was called Moab. Although there was plenty of food there, the people who lived there did not worship God. Naomi's two sons grew up and married young ladies who worshipped other gods.

Then one day something very sad happened to Naomi. First, her husband Elimelech died, and then her two sons died. Naomi's heart was filled with sadness. She was lonely too. She had heard that the rains had come again to Israel, so decided to go back to be among her own people.

Naomi told the wives of her two sons. The wives names were Orpah and Ruth. They wanted to come with Naomi. They all got ready for the journey and started walking.

After a while, Naomi stopped. She turned to her two daughters-in-law and said, "You have been very kind to me. Do not feel that you must take care of me any longer. You are young and I am old. Go back to your own people and be happy."

Orpah kissed Naomi and then went back to her own people. But Ruth did not. Naomi said, "Look, Orpah has gone back to her people and to her gods. Go and follow her."

What was Ruth's reply?

Find out from Ruth 1:16-18

So Ruth and Naomi went back to Israel. They got there just at the beginning of the grain harvest. In those days people were allowed to gather the left over grain from the fields, after

the farmers had cut it. This is what Ruth and Naomi did. What ever grain they picked up they were allowed to keep for themselves.

One day Ruth went into the fields of a very rich man named Boaz. When Boaz saw Ruth working in his field he wanted to find out who she was. One of the field workers said, "Her name is Ruth. She came with Naomi from a country far away. She asked me if she could pick up grain in our fields for herself and Naomi."

Then Boaz went over to Ruth and said, "I have heard about you, Ruth. I have heard of your kindness and faithfulness to Naomi. I am glad to have you as a worker in my fields. You may drink from my well and eat with the women who work for me if you wish."

Ruth thanked Boaz. Boaz told his workers to leave some grain so that Ruth and Naomi would have plenty to pick up.

Boaz grew to love Ruth very much. One day he asked Ruth to be his wife. Ruth loved Boaz too and was happy to marry him. Ruth and Naomi went to live at the house of Boaz. The Lord was happy with Ruth for being so faithful. He gave Ruth a little son named Obed. Obed became the grandfather of King David.

Discussion

Look at the two greatest commandments given to us by Jesus. (*Read Luke 10:27*)

Ruth obeyed both of these commandments. She could have chosen to go back to her own people who worshipped other gods, but instead she chose to follow Naomi who worshipped the true God. In doing this she was showing that she wanted to love God with all her heart. She also showed a great love for Naomi by deciding to go with her to a new land.

To love someone faithfully as Ruth did, means that we never stop loving. God is like that. People sometimes stop loving, but God never stops loving us. He is always with us, by our side.

The Bible says that there is a friend who is closer than a brother. (Proverbs 18:24) That friend is Jesus.

Think...

Which of these would be examples of faithful love?

Person 1

"Darren has better toys than my best friend James. I think I'll play with Darren instead."

Person 2

"Amanda is not very good at ball games. Never mind. She's a good friend so today I'll do what she wants to do."

Person 3

"It's too boring visiting Grandma. She's too old to play with me these days. I think I'll stay home."

God is love 5.4

Subtheme

God wants us to love others.

Bible references

John 4:1-30 The woman at the well.

Matthew 9:10-12; Luke 5:30 Jesus, friend of publicans and sinners.

1 Corinthians 13:4-7 Love is patient and kind.

Focus

Seeing people through the eyes of Christ; loving and accepting people as Jesus did.

Songs

God Loves You (*All Creation Sings*)

Clap Your Hands (*All Creation Sings*)

Wide Wide as the Ocean (*Sing A Joyful Song*)

Jesus is a Friend (*Sing A Joyful Song*)

Down in my Heart (*Couldn't Be Finer*)

Introduction: Experiment with 'seeing differently'

- Cover the lenses of some sun glasses with coloured cellophane. Try a different colour for each lens.
- Try looking through a magnifying glass.

Seeing through the eyes of Christ

(A play reading)

SCENE 1

Mum:

"How was your day at school?"

John:

"O.K. I guess. There was a new boy there today."

Mum:

"What was he like?"

John:

"Awful Mum. Nobody likes him. He is dirty and he looks at you with a real mean look every time you go near him."

Mum:

"Did anyone talk to him? You should try to get to know him a bit. Maybe he was just not feeling too sure of himself."

John:

"No way. He'd probably punch anyone who went near him."

Mum:

You and your friends seem to know this boy pretty well, considering that not one of you has spoken to him."

John:

"Well, sometimes you just know."

Mum:

Maybe what you need is for Jesus to help you see this boy differently."

John:

"What do you mean?"

Mum:

"Well, God wants us to LOVE other people."

John:

Oh, but He doesn't mean this kid."

Mum:

"Why not?"

John:

"Well, I'm sure he's not a Christian. He swears! I've heard him, Mum. He's a real creep."

Mum:

God wants us to LOVE others...Christian or not."

John:

I can't. He's not my type. Besides, the others would think I'd gone off my rocker if I started to be friendly with him."

Mum:

"If you asked God to help you, I'm sure you'd be able to see this boy with new eyes."

John:

"What do you mean?"

Mum:

"Just try it."

SCENE 2

That night in bed...

John: *(praying)*

"O.K. Lord. I guess I don't really feel too good about the way I've treated Sam. But I can't really help not liking him much. If you want me to like him you're going to have to help me see him differently."

Asleep and dreaming... two children wearing glasses...

Child 1:

"Hey, these new glasses are terrific. Suddenly I see the whole world differently."

Child 2:

"Yes. Isn't it great? I don't know why, but suddenly I find myself talking to people who I previously had no time for, and I'm enjoying it! There's a lot more to these people than I ever imagined."

Child 1:

"They make me feel all warm inside, and there's so much I could just never see before I had these."

John:

"Hey, where did you get those glasses? Can I try a pair?"

Child 2:

Oh, I'm sorry. They're all specially fitted by the Teacher. They only fit the person for whom they're made. Even then they have to keep going back for re-adjustment."

John:

"That must be a bit of a nuisance."

Child 2:

"Oh, no. It's terrific. Every time we go for an adjustment, we come back able to see more and more wonderful things that we've never been able to see before."

John:

"Wow! I'd like to get a pair of these glasses. Are they expensive?"

Child 2:

"Oh no they're free."

John:

"Well, tell me where to go and I'll get a pair. Who is this Teacher? Where does He live? He'd give me a pair wouldn't he?"

Child 2:

www.beaconmedia.com.au

"Well, that depends."

John:

"On what?"

Child 2:

"On whether you really want them."

John:

"Of course I want them. I said so didn't I?"

Child 2:

"But there's a price."

John:

"But you said they were free."

Child 2:

"Well, yes and no. You have to WANT to see people differently, as the Teacher sees them. He only gives glasses to those who believe in Him, and want to be like Him, and see like Him. If you see like the Teacher, you will no longer see people the same way as some of your friends do."

John:

"That's a problem. Maybe my friends won't like me if I see things differently to them. But I do WANT these new eyes. I do want to see differently."

Child 2:

"O.K. Let's ask the Teacher."

John:

Where is He?

Child 2:

He's everywhere and hears every word we say. Just ask Him to give you those special eyes."

John:

"Please Sir, let me see things with Your special eyes."

(Looking around:) "Wow! I've got them. Let's go and try them out."

Child 2: *(taking John to meet the new boy...)*

"I think you know this boy."

John:

"Hello. I'm sorry we were all so mean to you yesterday. Where do you live? Maybe I could show you around the district after school today."

Sam:

"O.K. I'd really like that."

John: *(to himself...)*

"Wow! What's happening to me. That's the same boy I saw yesterday. He's not too bad after all. In fact I really like him. It's like a dream."

SCENE 3

Mum:

"Wake up John. You're going to be late for school."

John: *(groping around...)*

"Where are my glasses?"

Mum:

"John, you've never worn glasses in your life. What are you talking about?"

John:

"The Teacher gave me His glasses so that I could see people in a new way...Ooh, it was only a dream."

Mum:

"Maybe not John. Did you pray the way I suggested last night?"

John:

"Well, yes."

Mum:

You may not be able to see the glasses, but perhaps they are there all the same."

John:

"You mean Jesus will help me see people differently?"

Mum:

"Why not?"

By Judy Martin (Used by permission)

Discussion

It is easy to be kind to those who treat us kindly. How about those who are unfriendly towards us? Should we still make an effort to be kind towards them?

Think about the fruit of gentleness.

Are we always gentle in the way we speak to others?

People can be hurt just as much by words as by actions.

God wants us to be loving in all that we say, even if the other person has spoken unkindly to us.

Story: The woman at the well

Jesus loved all people. He didn't just favour the good people. He didn't criticise people, as the Pharisees did, for failing to keep the laws. Jesus showed love and kindness towards people who were hated by others. Zacchaeus was one. Jesus showed kindness towards people who did wrong. He tried to help them. He tried to show them that God would forgive them if they were truly sorry. Jesus offered forgiveness to everyone who asked for it, no matter how bad they had been.

There is a true story in the Bible about a woman who Jesus met at a well. People did not have taps in their houses in those days so everyone had to go to the village well to get their water. It was a meeting place where women would talk together as they collected their water in their clay jars. There was one woman who everyone talked about. She was not a good woman. She lived with a man who was not her husband. For that reason no one talked to her.

There was another reason no one talked to this woman. She was a Samaritan. Jewish people did not like people from Samaria. However, there was one person who did talk to her. That was Jesus.

"Will you give me a drink from your water jar," asked Jesus. "I am thirsty and don't have a water container myself."

The woman was surprised. "Why are you talking to me?" she asked. "You are a Jew and I am a Samaritan."

Jesus told the woman of the special gift that God could give her. Jesus could forgive her and give her a special peace and joy inside. Jesus called this gift 'Living Water'.

Jesus knew how the woman lived. It was not God's way. He told her about her life, but not unkindly. The woman was surprised because no one had ever told Jesus these things. She knew that Jesus was special. "Could He be the One sent from God?...the One that the Scriptures spoke about?"

She knew that Jesus was the One. Yes, she wanted the 'Living Water'.

Discussion

The Pharisees thought that people were only worthy of being loved if they did the right thing. How did Jesus show a new way of loving?

Puzzle Code

A=26 B=25 C=24 D=23 E=22 F=21 G=20
H=19 I=18 J=17 K=16 L=15 M=14 N=13 O=12
P=11 Q=10 R=9 S=8 T=7 U=6 V=5 W=4
X=3 Y=2 Z=1

Using the puzzle code, work out this message:

15.12.5.22 18.8. 11.26.7.18.22.13.7 26.13.23.
16.18.13.23. 18.7 16.22.22.11.8 13.12
9.22.24.12.9.23
12.21 4.9.12.13.20.8

Brainstorm

Make a list of actions that show love.

EXAMPLE

Love is...sharing

Love is...forgiving

Love is...planning a nice surprise for someone

Art/Craft

Make a shield or badge with the words, "Love is patient and kind."

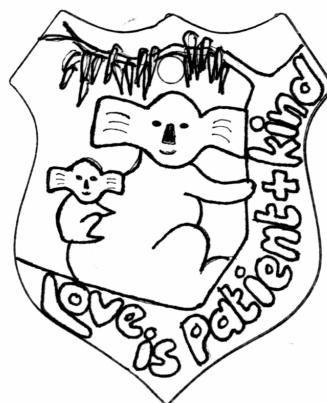

God is Wise

Level 5 (age 9)

Subtheme

It is wise to be prepared



*Go to the ant...consider her ways and be wise.
Proverbs 6:6 (KJV)*

Integrated topics for Christian Education

- Wisdom in being prepared: Planning for holidays/ travel/ natural disasters
- Wisdom of the ant, in being prepared. (Proverbs 6:6)

Other

- civil laws
- environmental responsibility; recycling; wise use of environment
- safety
- stranger danger
- money; banking; shopping
- planning for the future; careers
- biographies of those who relied on God for guidance and wisdom
- technology; inventions (God's wisdom given to man)
- journeys/exploration: people who relied on God's wisdom and guidance.
- preparation for outdoor activities e.g. hiking, orienteering
- preparation for seasonal weather conditions
- wise use of money; banking; consumer education.
- wise choices and decisions: choosing friends; drugs and alcohol

Character Development *(See Jesus First)*

- wisdom
- obedience

Christian Life

Our response to *God is Wise*

- acknowledging that God knows more than we do
- allowing Him to be in charge of our life

God is Wise 5.1

Subtheme

It is wise to be prepared

Focus

Wise and responsible behaviour

Bible references

Proverbs 6:6 The wisdom of the ant.

Proverbs 19:5 Warning against laziness

Matthew 6:19-21 Wisdom in storing up heavenly treasure.

Matthew 7:24-28 The wise and foolish builders.

Songs

He's Wiser (*All Creation Sings*)

My Dad (*Sing A Joyful Song*)

Jesus Show us the Way (*Sing A Joyful Song*)

The House on the Rock (*All Creation Sings*)

Discussion

Think about ways in which you would prepare for these things:

a) a family holiday

Make a list of the things you would need...

- for a summer camping holiday by the beach.
- for a holiday in the snow.

b) different kinds of weather

How do people prepare for bushfires? droughts? hot sun? floods? cold weather? snow?

c) earthquakes

How do people measure the likelihood of an earthquake in a particular area? How do people prepare for it? What precautions would be taken by town planners? What kind of buildings might be chosen in earthquake prone areas? How might an earthquake drill be carried out in a school? What preparations would be made by emergency services?

In order to prepare for the future we need to think ahead. Thinking ahead is being wise and responsible. It is opposite to being lazy.

Proverbs 19:15 says that laziness makes us sleepy. It prevents us from being aware of the future. Can you think of ways in which you can be wise and responsible around the home?

The Bible also gives us an example of little creatures which are very responsible. Read about them in Proverbs 6:6.

Story 1: The Ant and the Grasshopper

One lovely summer day a grasshopper was sitting in the sun singing with all his might. Nearby an ant was struggling along carrying a grain of wheat.

"Isn't it a beautiful day?" sang the grasshopper. "Why don't you sing like me?"

"I'm too busy," muttered the ant as he scurried along.

"What are you too busy about?" asked the grasshopper.

"I'm getting ready for the winter," replied the ant as he put a grain of wheat into his little store hole. Then off he went to fetch some more food.

"Well, I think you're silly," said the grasshopper as the ant returned with another grain. "As long as the sun shines I shall go on singing."

And so he did. But it wasn't long before Autumn came, and then Winter. The sun no longer shone and the cold winds blew. The green grass had turned to brown. Soon it became covered with a light dusting of snow. The leaves had fallen from the trees and had blown away. There was nothing to eat. The grasshopper was shivering with cold and was dreadfully hungry.

The ant, however, was snug and warm inside his hole with all the good food he had collected.

"Please give me some of your food," the grasshopper called down the hole. "I am so hungry."

"No, I can't," said the ant. "I should like to help you, but it has taken me all my time to collect this food and I need it to last me the winter. I have none to spare for anyone else. You should have prepared for the winter as I did."

From Aesop's Fables

Discussion

1. Why did the grasshopper think the ant was silly?
2. How did the grasshopper feel when winter came?
3. Why couldn't the ant give the grasshopper any food?
4. Why could you say the ant was wise?

Ants, like many other creatures, prepare for the future by storing up food. They are wise little creatures because they work hard and think ahead. God says that people should learn a lesson from the ant. People can be prepared for the future by inviting Jesus into their lives. Then, no matter what happens in the future God will be with them. Christians can prepare for the future by storing God's word in their hearts. (Read Matthew 6:19-21).

Story 2: The Wise and Foolish Builders

Read or tell the story from Matthew 7:24-28.

Discussion

Do you think that the foolish builder really believed that the floods would come? He probably thought that building on the sand was easier anyhow.

Perhaps many people refuse to build their lives on Jesus, the solid foundation, because they don't believe they will ever need Him. They think that it is easier to live a life doing exactly what they want to do, without having to give any time to God. Is this wise thinking?

Art/Craft

Make this free-standing model of an ant. Make sure that it is symmetrical. Fold down the centre, and write a message from Proverbs 6:6 inside.

OR you may prefer to make your own paper-mache ant.

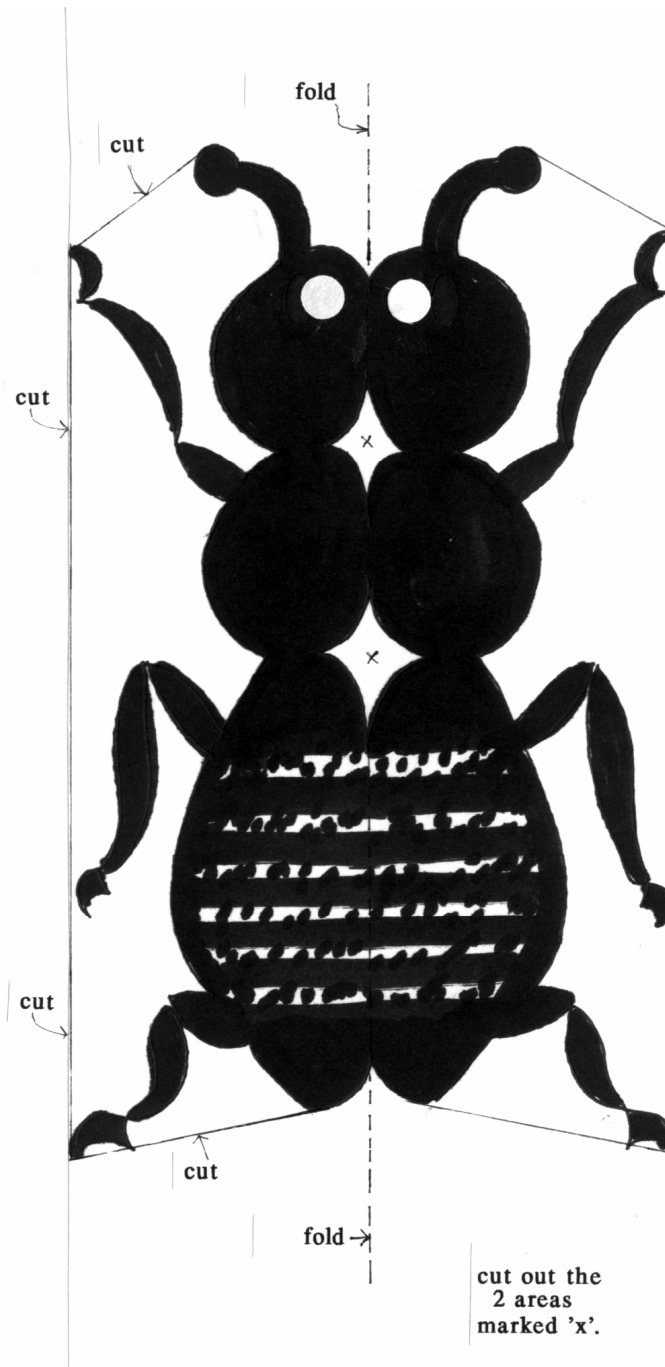

God is Wise 5.2

Subtheme

It is wise to be prepared.

Focus

Be prepared for Jesus.

Bible references

Matthew 25:1-13 The ten girls and their lamps.

Revelation 3:20 Jesus knocks at the door of our heart.

Songs

He's Wiser (*All Creation Sings*)

Jesus Show us the Way (*Sing A Joyful Song*)

Discussion

Think about ways in which children prepare for being a grown-up. Going to school is one way of preparing for the future. You learn things at school that will help you to get a job one day. When you finish school there is still more to learn. Nurses, architects, pilots, teachers and astronauts all need much preparation for their jobs.

Story 1: Be Prepared

Astronauts must train on earth before they can go into space. They practice working under water, because floating in water is like floating in space. They work, eat and drink inside a full-sized model of a spacecraft which is submerged in a huge water tank.

They must also practice for lift-off and landing. A machine called a centrifuge spins the astronauts around very fast. Spinning gives them the same hard push they will feel when their spacecraft lifts off and zooms upward.

Astronauts need to be very fit. They prepare their bodies by intensive exercise programs. There is lots to know about the space voyage and operating the spacecraft so they spend a lot of time learning and studying.

For some astronauts, the experience of being in space causes them to think about the wonder of the creation. For one astronaut named Charles Duke, his time in space brought him closer to God than ever before. As he thought about the great God of the universe, he suddenly realised that he was not prepared to meet Him. Although he had spent so much time preparing for the space voyage, he had never given time to God. It was because of this voyage that Charles decided to give his life to Jesus.

Story 2: The ten girls and their lamps

This is a parable about some girls who were not prepared for the future. Read the story from Matthew 25:1-13. Five were prepared for the journey but five were not.

Jesus wants us to prepare our hearts for the future. We can prepare our mind by learning and we can prepare our bodies by healthy eating and exercise, but there is only one way to prepare our heart. Find out about this from Revelation 3:20.

Five of the ten girls were not prepared for the future. Jesus told this story to show us that we must be prepared for the day when He comes again. We will be prepared if we have asked Jesus to forgive us for our sin and to be our special friend.

Art/Craft

Make a paper lantern.

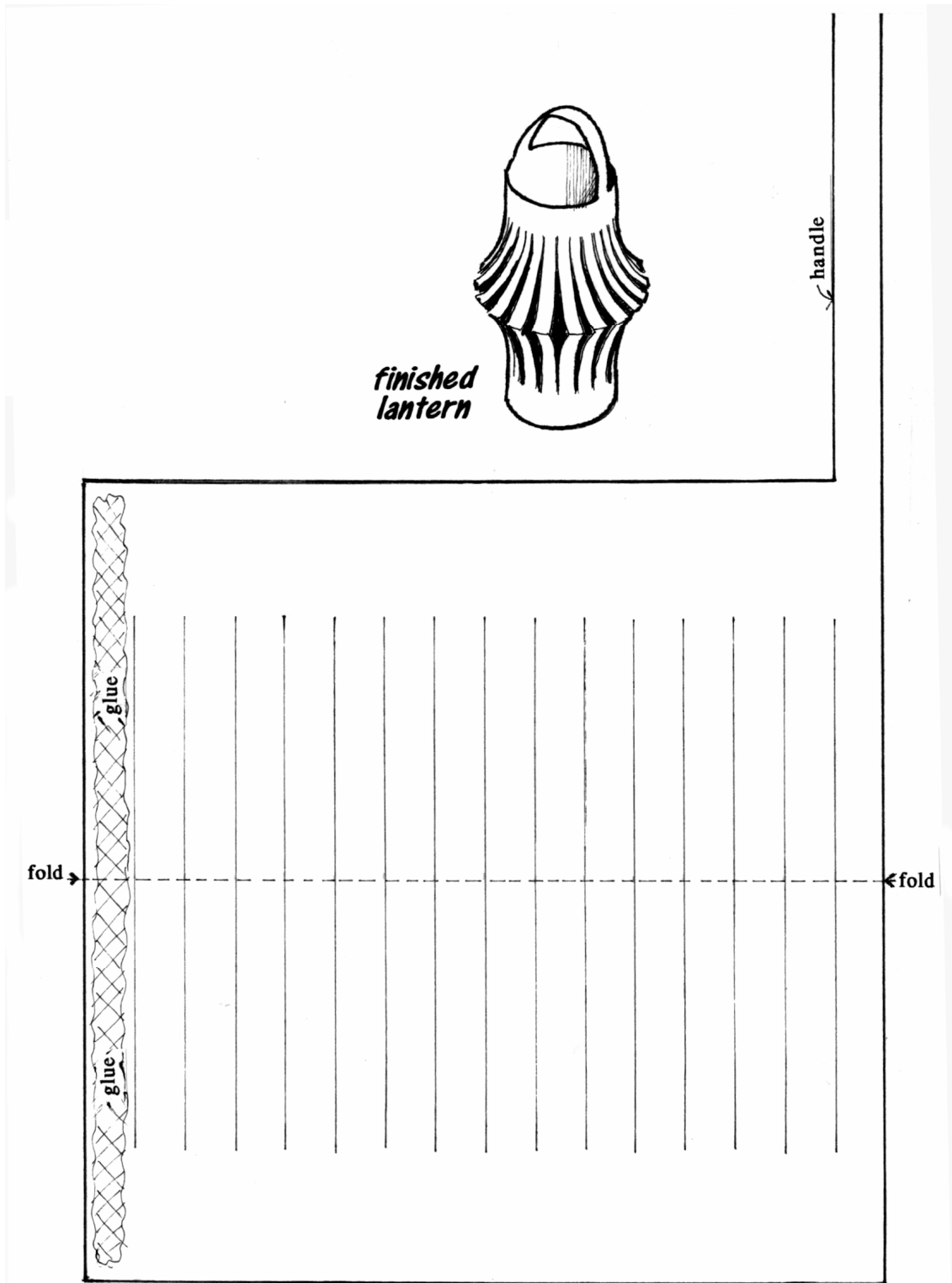

God is Protector

Level 5 (age 9)

Subtheme

God rescues His people and protects them from sickness.

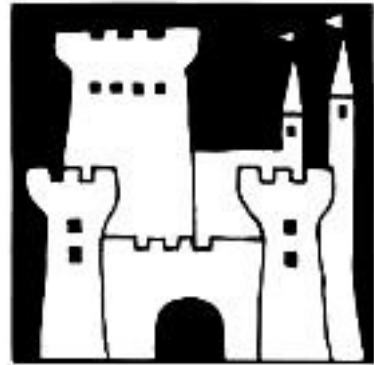

*The name of the Lord is a strong tower. The righteous run into it and are safe.
Proverbs 18:10*

Integrated topics for Christian Education

How animals protect themselves: camouflage, skeletons, defence mechanisms.

Other

- family
- shelter: history of buildings;
- protection services e.g. police; firemen
- castles; fortresses; armour and weapons; the armour of God.
- sea voyages, ships and lighthouses
- environmental protection: saving animals on the verge of extinction
- human biology: protective mechanisms of the human body; hygiene and protection against bacteria

Character Development *(See Jesus First)*

- security
- courage

Christian Life

Our response to *God is Protector*

- trusting in God as Father
- feeling safe and secure in His care

God is Protector 5.1

Subtheme

God protects us from harm and evil

Focus

Angels protect us and fight for us.

Bible references

Psalm 91 Angels protect us.

Psalm 23 The Lord is my Shepherd.

Ephesians 6:10-18 The armour of God.

2 Kings 6 Elisha and God's army of angels

Songs

I Don't Have to Worry (*Sing A Joyful Song*)

A Great Big Dad (*Couldn't Be Finer*)

The Lighthouse Song (*All Creation Sings*)

Introduction: angels

In this exercise children will act out the role of an angel. You will need some pre-recorded instrumental music, (preferably music that will create a calm atmosphere.)

Children work in pairs. One child in each pair is a guardian angel to the other person. While the music is playing, the angel leads his/her partner on a journey, using mime to warn the other of the dangers along the way. For example, the angel can signal when to stop because of danger, and when it is safe to continue. The angel can point out obstacles to walk around or jump over. Sometimes the angel may go ahead of their partner indicating that the partner must follow. Sometimes the angel may allow the partner to move freely, but keeping a watch for dangers.

Discussion

What are angels?

Why did God create them?

Which people in the Bible saw angels?

Angels were often sent as messengers. Sometimes the message was for the safety of that person. For example, Joseph was warned of Herod's intention to harm the baby Jesus. He was told to escape with Mary and the baby into Egypt.

Angels mentioned in the Old Testament often protected God's people against the enemy. In Old Testament times, God's people had many enemies. The enemies worshipped false gods, and were always wanting to destroy God's people. Here is a story about a time when God sent angels to save them.

Story: God's army of angels

The king of Syria wanted to make war with Israel. He organised his men to set up camp in a place where they could easily capture some of the Israelite soldiers.

There was an Israelite called Elisha who had the special gift of being able to hear messages from God. God told Elisha what the king of Syria was planning to do. God told Elisha where the Syrian camp was. Elisha went straight to the Israelite king to warn him. The Israelite

army were able to keep well away from the Syrian camp, so the Syrians couldn't capture them.

The Syrians tried again and again, but each time the Lord showed Elisha their plans. Each time they avoided the Syrians. Finally, the Syrian king called his soldiers together and said, "Which one of you is a spy, and telling the Israelites our plans?"

One of the soldiers replied, "There are no spies amongst us, but there is an Israelite named Elisha who hears messages from God. He knows your plans and tells them to the Israelite king."

The Syrian king was very angry. He found out where Elisha lived. The king and his men came by night with their horses and chariots and surrounded the town where Elisha lived.

The next morning, when Elisha and his servant got up, they saw horses and chariots everywhere!

"Don't worry," said Elisha. "We have more soldiers with us than they have with them. (But the servant saw no soldiers with Elisha, as the Israelite army was based in another place called Samaria.)

Then Elisha asked God to open the servant's eyes. God opened his eyes and he saw horses and chariots of fire, there with them on the mountain. It was God's army of angels. God had sent his angels to fight for Elisha.

Then Elisha spoke to the king of Syria. "Is it Elisha you are looking for? He does not live here. Let me take you to him."

The king and his army followed Elisha all the way to Samaria without realising that it was actually Elisha they were following. Elisha led them right into the Israelite camp. When the Syrians realized where they were they were terribly afraid. There were now more Israelite soldiers than Syrians.

"What shall we do?" the Israelite king asked Elisha. "Shall we kill them?"
"No," said Elisha. "Let them go free."

So Elisha sent the Syrian army home, and they did not bother the Israelites for a long time after that.

Discussion

1. What was Elisha's special gift?
2. How did God protect the Israelites?
3. What did the Syrian king do when he found out that Elisha knew their plans?
4. How did God protect Elisha?
5. Did the servant see the angel army at first?
6. What did he see when God opened his eyes?
7. What did Elisha say to the Israelite king once they were in the hands of the Israelites?
8. Could it be possible that armies of angels protect us, even though we can't see them?
9. Write about a time when angels may have protected you.

Bible research

Read Psalm 91 or Psalm 23. Which verses tell us about God's protection?

God is Protector 5.2

Subtheme

God protects us from harm and evil

Bible references

Psalm 4:8 God makes us dwell in safety.

Psalm 27 The Lord is my light...Whom shall I fear?

Isaiah 41:10 Fear not, for I am with you.

Isaiah 43:1-2 You will walk through the fire and not be burned.

Daniel 3 Three men in the fiery furnace

Acts 5:29 We ought to obey God rather than men.

Focus

God protects those who obey Him.

Songs

A Great Big Dad (*Couldn't Be Finer*)

I Don't Have to Worry (*Sing A Joyful Song*)

Introduction

Who does God protect?

Would He protect a bank robber?

God has an army of helpers who watch over God's children. Who are they?

Act it out

Two nasty characters are scheming an evil plot. They are hiding in a lane way and intend to rob the next person who walks down the street.

Mr. X walks along. He is a Christian.

God knows about the robbers' plan, so sends an angel to tell Mr. X to go another way.

The next person to walk along is a policeman. He spots the two robbers and takes them off to the police station.

Story: Three men in the fiery furnace

Daniel was a man who faithfully served God. Like Elisha, he had the special gift of hearing what God had to say.

The king, in those days, was king Nebuchadnezzar. One time, when Daniel was away, the king made a huge golden statue. He set it up on an open plain and commanded that everyone bow down and worship the statue.

Read Daniel 3, verses 4-6.

What would happen to anyone who didn't worship the statue?

If Daniel had been there he would have refused to worship the statue. Daniel was not there, but his three friends were. Their names were Shadrach, Meshach and Abednego. Like Daniel, they loved and obeyed God, and of course, refused to worship the golden statue.

What happened when the king found out that they would not worship the statue?

Read verses 13-15.

Still they did not worship the statue. What happened next?
Read verses 19-30.
Who did God send to protect the three men? (verse 28)

More Bible research

Acts 5:29

When should people obey God rather than men? Was it right for the three men to disobey the king?

Isaiah 43:1-2

Walking through dangerous waters and fires could stand for any dangerous circumstance we find ourselves in. What does God promise?

Activity

Make a jigsaw puzzle from this Bible text.



God is Protector 5.3

Subtheme

God protects us from harm and evil

Bible references

Psalm 37:7 Don't be afraid of evil doers.

Proverbs 3:5-6 Trust in the Lord with all your heart.

Acts 12:1-19 An angel saves Peter

Focus

God protects those who trust in Him.

Songs

The Lighthouse Song (*Sing A Joyful Song*)

I Don't Have to Worry (*Sing A Joyful Song*)

A Great Big Dad (*Couldn't Be Finer*)

Introduction

Look at a picture, or imagine, a lighthouse. Why could we say that a lighthouse is a symbol of protection?

Story 1: An angel saves Peter

King Herod had previously tried to kill the baby Jesus. Now, some years later, he was throwing the followers of Jesus into prison. Peter was one.

King Herod intended to persecute Peter. This meant Peter would be whipped or stoned for being a Christian. However, God sent an angel to protect him. The angel helped him escape.

Read the story from Acts 12:1-19

Discussion

Who was praying for Peter's protection? (Acts 12:5)

Does God expect us to pray for protection?

Think of some situations where we may need to pray for protection.

Some Christians go as missionaries to places where there are poor conditions and contagious diseases. Others have taken Bibles to places where Christianity is forbidden. If caught speaking about Jesus or giving away Bibles they would be in serious trouble.

Story 2: Tomorrow you Die

(A true story)

Introduction to the story:

Find the country of Albania on the map. Briefly discuss the problems faced by Christians in country where Christianity is forbidden.



Reona Peterson and her friend Evey had a dangerous mission to accomplish. God had called them to take His message of love into the country of Albania. In 1973, when this story took place, the Albanian government had a strong hatred for Christians. People were forbidden by law to believe in the God of the Bible. People were expected to honour and obey the government above everything else. Reona had been a teacher from New Zealand, and Evey, a nurse from England. The only way they could get into Albania was with a tour group. Tour groups were seldom allowed into Albania, but the two ladies finally found a French group leaving for Albania that summer.

They boarded the bus in Paris, travelled through France, then Italy and Yugoslavia. As they crossed the border between Yugoslavia and Albania, they sensed the danger that lay ahead. Through the bus window they could see a cluster of white concrete buildings and a large red and black flag fluttering from a flag pole. Without warning, the bus stopped. Within seconds they were surrounded by soldiers with guns at their sides. All those on board were asked to get off. Clothing was checked carefully. Anyone with bright, conspicuous clothing had to change immediately. Luggage was searched, then visas checked.

Finally they were on the bus again, heading for their hotel. On arrival, they were assigned three to a room. Reona and Evey were joined by a British woman named Mary.

"This is my second trip to Albania," said Mary. "On my last trip, six years ago, two members of the group were interrogated for carrying Christian books and leaflets. That's the thing they're after."

Reona and Evey froze as they thought of the small New Testaments and Christian leaflets they were carrying in their shoulder bags. The bags had concealed compartments where the Bibles and leaflets could be hidden quite well.

After a few days the tour party visited the city of Tirana. The guide surprised everyone with the news that they had two hours walk in the city. The tourists were allowed to go off on their own instead of being supervised as usual. There were several parks in the city. Reona and Evey made their way to these, leaving Christian leaflets on benches, on tops of hedges, or on walls of fountains. While walking in the city they met a man who spoke French. This was unusual, as most people here spoke only Albanian. Both Reona and Evey knew some French so they were able to tell him about Jesus.

"I know it and believe it," said the man in French. He was a secret believer. How glad he was to meet some other Christians.

One night, towards the end of the tour, Reona and Evey were returning to their hotel, when Reona felt ill. She had a terrible night with severe stomach pains. By morning, she knew that

she could not join the party for the two-day excursion, which had been planned. Evey would have to go alone.

At lunch time, a woman came into the room with a food tray. Reona knew what she must say try to tell the woman about Jesus. Tears came to the woman's eyes.

"Me Christian too," she said in broken English.

Reona gave her a New Testament.

About four O'clock there was another knock at the door. Reona was expecting the waitress again, but instead it was a stern-faced man who demanded that Reona come down stairs for interrogation.

Grabbing her dressing gown she followed the man downstairs to a small room where a special chair awaited her. A copy of a New Testament was placed on the table in front of her.

"Have you seen this before?" asked the chief interrogator.

Reona said that she had.

"The one who received this from you has betrayed you," said the interrogator.

Reona did not believe this. The truth was that the Christian waitress had left it lying about somewhere.

"Why did you come to Albania?" continued the interrogator. "Don't you know that no one in Albania believes in God? You will never see your family again. You are a traitor to our government, and traitors are shot. We will come for you at nine O'clock tomorrow morning."

Photographs were taken, and Reona was led back to her room. Reona lay on her bed and prayed, "Lord Jesus," she said, "It will be a privilege to lay down my life for you."

When the next day arrived, Reona was interrogated once more. Then the tour party returned and Evey was interrogated as well. During Evey's eight hours of interrogation she tried to take every opportunity to talk about God.

"Don't mention God again!" roared the interrogator angrily.

The French tour guide knew the situation the women were in and tried to be helpful. He assured them that he would do everything he could to try to get them released.

The next morning, Reona and Evey were told that they would be released.

"We will drive them to the border and leave them there. Never again will they be allowed to enter Albania," was the announcement to the group. However, after the group departed, the women were interrogated again.

"So you thought you were free! There are still more questions for you to answer," said the chief.

Had the announcement of their release just been to fool the group into thinking they were free? Did the authorities have other plans for them?

Finally they were given some forms to sign concerning the crimes they had committed, then they were ushered into a car. The car drove for about half an hour and then stopped. The ladies did not know where they were being taken. The two interrogators got out and the car continued. Could this be the road leading to the border, or was it leading to a prison?

Finally they passed through a town that they recognised. They knew they were only half an hour from the border. On arriving at the border their passports were stamped, 'PERSONAE NON GRATA', (a person forbidden to enter the country again).

"You may go," said a voice.

The two women walked through the gates into 'no-man's land'. This was an area of swampy country between Albania and Yugoslavia, a zone belonging to neither country. The Yugoslavian border was still about ten kilometres away. How could they ever find their way?

It was not long before a car pulled up.

"Taxi?" said a young man.

"No dinar," said Reona, meaning 'no money'.

The car drove back in the direction that it had come. Soon the car returned. The young man got out, took their suitcases and motioned to the women to get in. This time they did not argue. The taxi drove them to the Yugoslavian border for no cost. "Why would a taxi driver do this?" they wondered. "Was he an angel in disguise?"

From here, another driver offered them a ride to Italy. They did not know the driver, but at the end of the journey he pushed into their hands a large number of silver coins. They had exactly enough money for the bus and train fare back to Switzerland, where Christian friends had been praying earnestly for the safety and protection of the two women.

Retold from TOMORROW YOU DIE by Reona Peterson. (Used by permission)

Prayer

Just as the church was praying for Peter, we need to pray for people who go into dangerous situations to do God's work. Pray for anyone you know who particularly needs God's protection.

Art/Craft

Work as a group to create a 3D seascape.

Use the lid of a shoe box or similar. Make some "rocks" from paper maché and then make a cardboard lighthouse to stand on the rocks. Model boats can also be made.

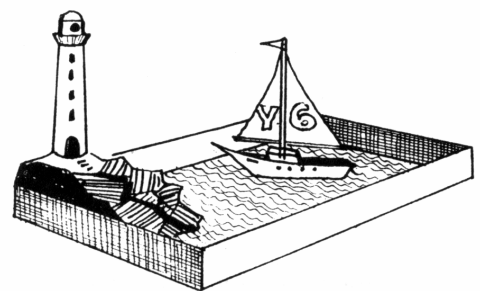

OR

Make a 2D lighthouse by cutting out the shape from heavy black paper. Back the cut-out sections with cellophane of various colours. Display on a window pane.

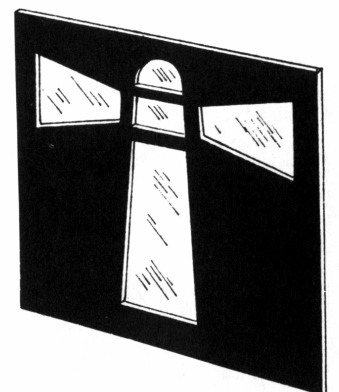

God is Powerful

Level 5 (age 9)

Subtheme

God has power to change things.

The Lord rules... greater than the roar of the oceans, more powerful than the waves of the sea. Psalm 93:4 (GNB)



Integrated topics for Christian Education

- Chemistry: observation of change
- States of matter; steam power; hydro-electric power

Other

- God's power seen in the creation: Force and energy; machines; tools; toys; transport.
- electricity magnetism
- solar system: expresses the greatness of God
- landforms: the power of creation expressed in mountains; volcanoes
- change: chemical reactions
- weather: powerful forces seen in storms; hurricanes
- transport; flight: utilizing the power forces in the Creation
- God's power to do miracles

Character Development *(See Jesus First)*

- faith
- surrender to a powerful God

Christian Life

- expecting to witness God's supernatural power in our lives
- allowing the Holy Spirit to work supernaturally through us
- relying on God's power and not our own strength

God is Powerful 5.1

Subtheme

God has power to change things

Focus

Jesus changed the lives of His followers.

Bible references

John 1:35-50; Matthew 4:18-21; Matthew 9:9-13 Jesus changed the lives of the first disciples.

Luke 19:9-13 Jesus changed the life of Zacchaeus.

Matthew 9:1-8 Jesus changed the life of a paralysed man.

Songs

God is Greater (*All Creation Sings*)

What A Mighty God (*All Creation Sings*)

No Man Was Like Him (*Sing A Joyful Song*)

More Like Jesus (*Couldn't Be Finer*)

King Of All (*Couldn't Be Finer*)

Introduction

Can you guess which insect this is?

It has a long body and four beautiful wings that shine in the sunlight. The wings reflect the colours of the rainbow. It lives around rivers, ponds and dams, and darts around with quick movements.

Answer: a dragonfly

The dragonflies that you see flying around on a sunny day did not start their life as such beautiful creatures. They actually began as little grubs that crawled around the muddy bottom of the dam. As the little grubs grew, they gradually changed into beautiful dragonflies.

Can you think of another creature that changes from a grub into an insect with beautiful wings?

Answer: a butterfly

God shows us through His creation that He has the power to change things.

What happens when you take an ice-block from the freezer and leave it on a saucer for a while?

You can also watch water changing from a boiling liquid to steam.

Just as God can change things in His creation, He can also change people.

Bible research

Jesus chose twelve men to be His closest friends. When Jesus called these men, they had to change their way of life. For Peter, Andrew, James and John, it meant giving up their fishing nets and becoming followers of Jesus.

Read Matthew 4:18-22

For Matthew, it meant leaving his life as a tax collector.

Read Matthew 9:9

Although he was not one of the twelve, Zacchaeus was a tax collector whose life changed when he met Jesus. How did his life change?
Read Luke 19:8

Jesus also changed the life of a paralyzed man. He not only healed him, but also forgave him.
Read Matthew 9:1-8

God still has power to change people's lives. He can change a sad life into a joyful one. For people who are lonely, he can give them friends. He can change us too when we give our life to Him and decide to follow Him.

What are some other ways in which God can change people?

Art/Craft

Draw the outline of a large dragonfly using white pencil on heavy black paper. Cut out the wings of the dragonfly and back the wing-shapes with coloured cellophane or tissue paper. Overlap colours of cellophane/tissue to make more colours. Display picture on window pane so that light shines through.

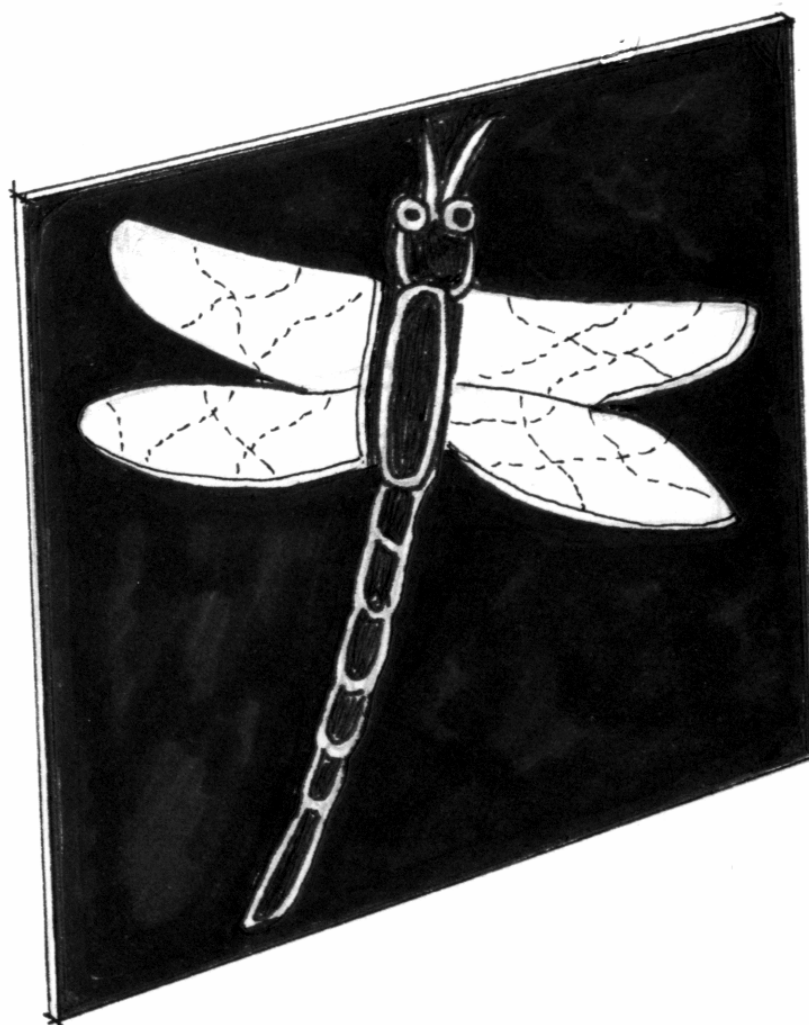

God is Powerful 5.2

Subtheme

God has power to change things

Focus

When someone becomes a Christian we expect to see a change in their life.

Bible references

Acts 9 Saul's conversion

Isaiah 62:2 You will be called by a new name, a name given by the Lord himself. (GNB)

Songs

God is Greater (*All Creation Sings*)

No Man Was Like Him (*Sing A Joyful Song*)

What a Mighty God (*All Creation Sings*)

Introduction

Make some popcorn.

While eating the popcorn, notice how the popcorn changes from a small, hard corn seed into something edible.

While eating the popcorn discuss ways in which some things in God's creation undergo change. Also discuss the way that people's lives can change when they become a Christian. Through God's power He can change us into the person He wants us to be.

Story 1: Under New Management

"Dad, John's shop is all different!" said Josh as he raced in the door after getting the milk from the shop.

"Different?" asked his Dad.

"Yes, it has all been changed around while we've been away," said Josh. "John is still there, which is good. But things have been moved around. And the shop's been painted a different colour."

"Does it look better?" asked his Dad.

"I think so," said Josh. "It is better set out, and cleaner. But I am so glad John still there. It wouldn't be the same without him."

And, there's a sign in the window, "Under New Management," added Josh. "What does that mean?"

"Well, I suppose it means that John still runs the shop, but he does not own it," explained his father. "The man who did own it has sold it to someone else. It looks as if the new owner made some changes."

"But it's still John's shop, isn't it?" asked Josh.

"Yes, if John is running it, it's still John's shop," agreed his Dad. "It's just that different people actually own it."

We read in the Bible in the book of Acts, that the disciples were under new management after the Holy Spirit came upon them. Things were different for them. That was clear from their changed lives. No longer were they frightened. Now they had a purpose. They knew

what they had to do. Now they were determined to speak about the Lord Jesus, even though to do so would probably mean persecution and imprisonment.

by Janine Stewart (for 'New Life') Used by permission

Discussion

Just as the Holy Spirit changed the lives of the disciples, He can change lives today. What differences might we notice about someone who has just become a Christian?

Story 2: Saul Becomes A Christian

Saul was not one of the disciples. In fact he hated Christians. He hated them so much that he persecuted them. However, something very unusual happened to him. Read about it in Acts 9:1-21.

Saul's life changed so much that God chose a new name for him. From then he was called Paul. We can also read about others in the Bible who had a change of name to show that their life had changed. One of these was Simon the fisherman, whose name was changed to Peter.

Not everyone has a change of name when they become a Christian, but they can have a change of life.

Activity

Find out the meaning of your name.
Make a card showing the meaning of your name.

Art/Craft

Make a picture. Draw or cut out a horse and rider to represent the story of Saul. Write a caption: "God's power changed Saul to Paul".

**God's power
changed
Saul to Paul**



God is Powerful 5.3

Subtheme

God has power to change things

Focus

God can provide an answer to our problems.

Bible references

John 2:1-12 God changed a difficult situation at the wedding at Cana.

2 Kings 5 God changed the life of the leper, Naaman.

Zechariah 4:6 The Lord says, "Not by might, or by your own strength, but by My Spirit, obstacles as great as mountains will disappear before you."

Jeremiah 32:17 Nothing is too difficult for You. (GNB)

Songs

What A Mighty God (*All Creation Sings*)

God is Greater (*All Creation Sings*)

No Man Was Like Him (*Sing A Joyful Song*)

Introduction

Find a task that is extremely difficult, e.g. unscrewing the lid of a jar which has been placed on very tightly; or untying a very difficult knot.

Discussion

There are some things that we find to be very difficult. Not just physical things, but other problems. Let's think about problems at school. Maybe it's a problem with school work. Maybe it's a problem with friends.

Whether our problems are big or small, God has the power to change things. When the problem is too big for us, by His power, He can find an answer to the problem.

Here are two stories about people who had problems.

Story 1: Naaman's Problem

Naaman had a big problem. It seemed as if there was no answer. It seemed as if his trouble would never go away.

Naaman had once been a strong healthy man. He had been commander of the king's army. He and his wife lived in a beautiful home. They were very rich. He used to be very happy. Then one day he became ill with an incurable, contagious disease called leprosy. A person with leprosy had running sores all over their body. No doctor could cure a leper.

Naaman's blistered and his hands and feet turned white as the dreadful disease started spreading over his body.

Naaman was a Syrian, not a Jew, But he did have a little Jewish servant girl who worked in his house.

"I know a servant of God who could help Naaman," said the little girl to Naaman's wife. "His name is Elisha. "God's power works through him and great things happen when he prays."

Naaman's wife told Naaman what the little girl had said. Naaman decided that he must go to the land of Israel to find this person called Elisha.

Naaman was good friends with the Syrian king. "Go to Israel," said the king. "I will give you a letter of recommendation."

So Naaman went to Israel with the letter, but the king of Israel did not welcome Naaman who was a Syrian. When Elisha heard about the king's visitor he said, "Send the captain to me."

Continue the story from 2 Kings 5:9-11

Naaman did not believe that washing in the Jordan seven times could make him better. He was very angry. However, Naaman's servants helped him to believe.

Read verses 13-15

When Naaman believed and obeyed God's words spoken through Elisha, Naaman was healed. He then understood the great power of God available to those who believe and obey God. God's power was greater than Naaman's problem.

Story 2: The Wedding at Cana

God is concerned about small problems too.

Once Jesus was at a wedding party with His family. Suddenly the drinks ran out. The shops were closed. It was impossible to get more.

Would the host have to serve water? How embarrassing! Mary had an idea. Perhaps Jesus could help!

Read about it John 2:1-12

Discussion

Although the problem faced by the host of the party was not as great as Naaman's, God still cared. Once again, God used His great power to solve a problem.

Whenever you have a problem...big or small...remember that God's power is greater than your problem.

Bible research

What do these verses say about God's power?

Zechariah 4:6

Jeremiah 32:17

Art/Craft

Make this pop-up card.

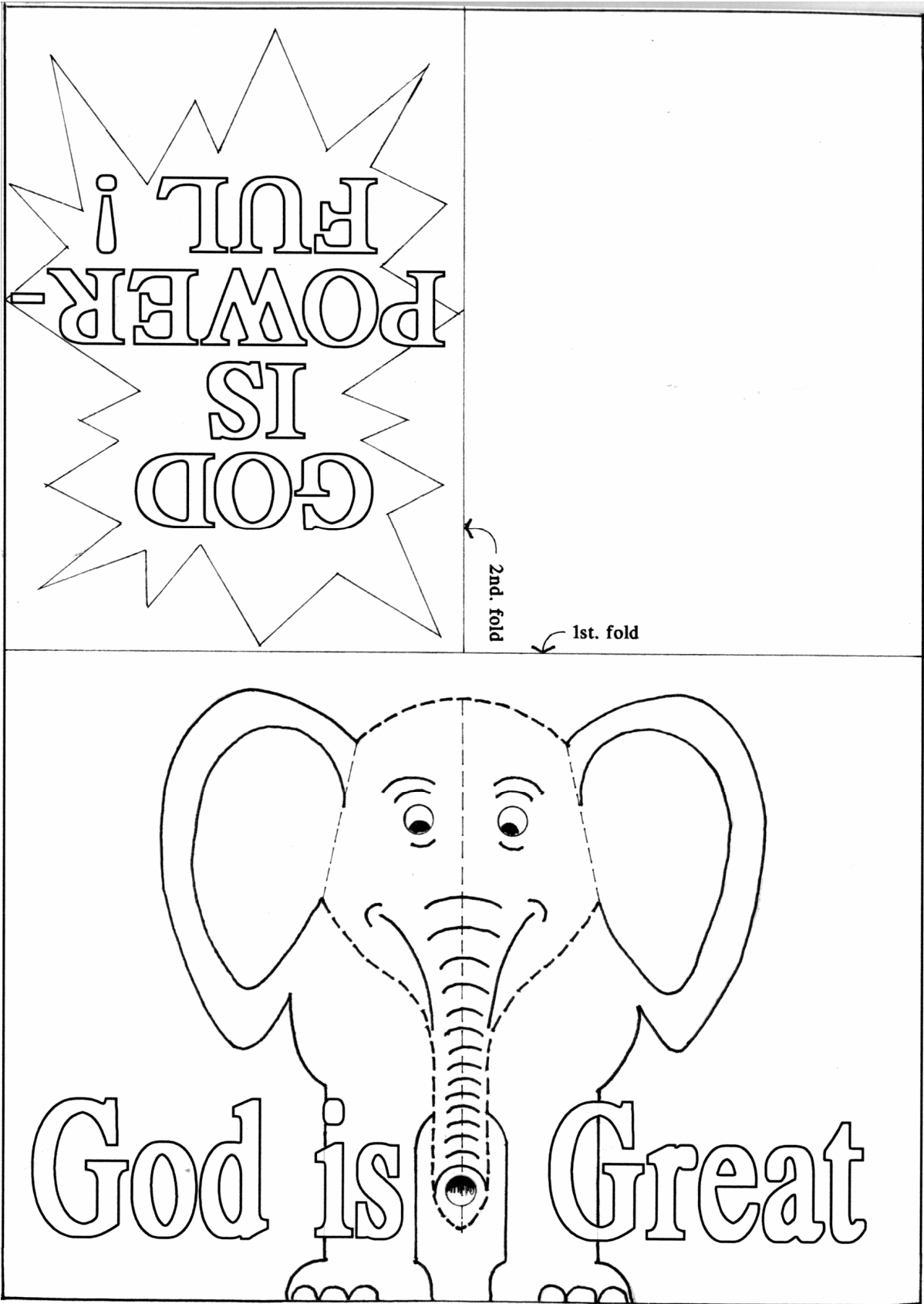

God is Truth

Level 5 (age 9)

Subtheme

True or false?

Live a life that measures up to the standard God set when He called you. Ephesians 4:1 (GNB)



Integrated topics for Christian Education

Scientists Galileo and Copernicus: discovery of truth about the solar system; telescopes, pendulums.

Other

- friendship: faithfulness, truthfulness and honesty
- discovering truth through the scientific method
- testing properties of matter to determine whether a substance is real or substitute
- literature studies: fact or fantasy?
- discovering the truth through archaeology
- creation science: scientists who seek the truth and gather evidence to show that the universe is not millions of years old.
- rock classification, identification, strength and durability. (Build your life on the Rock!)
- the media and advertising; consumer education: honesty/dishonesty in advertising and packaging; deception through advertising; customer surveys; testing performance of products.

Character Development *(See Jesus First)*

- honesty
- discernment

Christian Life

- believing God's Word
- obeying God's Word

God is Truth 5.1

Subtheme

True or false?

Focus

Satan tries to lead us away from truth.

Bible references

Matthew 4:1-11 Jesus tempted by Satan.

1 John 4:1 Don't believe every spirit.

2 Corinthians 11:14 Satan is an angel of light.

John 8:44 Satan is the father of lies.

Genesis 3:1 The snake was very clever.

Ephesians 6:11 Satan is deceitful.

James 4:7 Resist the devil.

Songs

Adam and Eve (*Couldn't Be Finer*)

Whatever is Good (*Couldn't Be Finer*)

The Good Shepherd (*Sing A Joyful Song*)

Jesus Show us the Way (*Sing A Joyful Song*)

Introduction

Show a \$20 note. How do we know whether the note is counterfeit or not?

People who forge notes try to make the counterfeit note identical to the original in every way. However there are some details that are very hard to copy, and a forged note can be identified by close examination of certain details.

Satan also tries to counterfeit things that are true. Sometimes it is easy to pick out the things Satan does because they just look evil. However sometimes Satan can trick people into following him because he makes things look GOOD. This is why the Bible says he is deceitful.

Bible research

Find out what the Bible says about Satan's deceitfulness in 2 Corinthians 11:3-4 & 13-15.

(Who was writing this?)

John 8:42-45 (Who was Jesus speaking to?)

Genesis 3:1-5 (How was Satan disguised? How did he trick the woman?)

Story: Jesus is tempted by Satan

Read the story from Matthew 4:1-11.

When Satan spoke to Jesus, he appeared to be telling the truth. After all, he was quoting from the Bible. The problem was, Satan was misusing God's word and Jesus knew this.

What did Jesus do to get rid of Satan?

What does God tell us to do? (Ephesians 6:11 and James 4:7)

Brainstorm

How does Satan trick people today?

Examples:

- false religions
- loving money and things more than God
- wanting to have a good time more than serving God
- pleasing yourself instead of God and others

Drama: The Way

Use the 'Brainstorm' as the basis for this drama.

One person is trying to find the way. Others along the path give false direction. Finally a Christian points the person to Jesus. The children may come up with other suggestions for types of 'deceivers'.

Searcher:

Excuse me, can you show me the way?

First deceiver:

"Yes, come with me. I know a huge toy store in the city where you can buy all the latest toys...and they give out free lollies with every purchase."

Searcher:

"Ah... no thanks."

Searcher:

Excuse me, can you show me the way?

Second deceiver:

"Yes. If you come with me to the clothing store we'll buy the latest outfits and look really cool."

Searcher:

"No thanks."

Searcher:

Excuse me. Can you show me the way?

Third deceiver:

"This is it! Computer games. Once you start you just can't stop. This is the way to REAL happiness!"

Searcher:

(Just stares at deceivers addiction and shakes head.)

Searcher:

Excuse me. Can you show me the way:

Christian: *(reading the Bible)*

"Yes. Jesus is the way. Look. It says right here in God's book that the only way to have truth and happiness forever is to follow God's Son, Jesus Christ!"

God is Truth 5.2

Subtheme

True or false?

Focus

Knowing the truth and seeking the things that are of true value.

Bible references

John 16:13 The Holy Spirit guides us into all truth.

John 1:32-34 The Holy Spirit rested on Jesus, as a sign that He was God's Son.

John 14:15-21 The Holy Spirit is the Spirit of truth.

1 John 5:6 The Spirit of truth

1 John 4:1 Don't believe every spirit.

John 18:37 Everyone of the truth hears my voice.

Songs

Adam and Eve (*Couldn't Be Finer*)

The Good Shepherd (*Sing A Joyful Song*)

Jesus, Show us the Way (*Sing A Joyful Song*)

Introduction: Fool's gold!

Take a stone and cover it with clear glue. Sprinkle gold glitter over the glue and allow it to dry.

Discussion

What is fool's gold?

Some rocks/soils contain tiny gold particles. People are often fooled into thinking it is gold, but really it is another mineral called iron pyrites.

What would you do if you found something that looked like gold?

If you are wise you would first find out whether it really is gold before getting too excited. Finding truth is a bit like finding gold, because truth, like gold, is very valuable. Just as people can mistake fool's gold for real gold, people can also make a mistake about finding truth. Many people think they have found truth, but they don't take time to find out what truth really is. The Bible tells us that Jesus is the truth and other gods are false. Living a Christian life is the only way to find truth.

Some things look great, but they are not at all. Have you ever had an inexpensive toy that has fallen to pieces in five minutes? Satan can make evil things look attractive, but they only make people happy for a short time. This is why the Bible calls Satan a liar and a deceiver. Only Jesus, who is the truth, gives people happiness that lasts forever.

Bible research

How can we KNOW the truth?

Jesus said that the Holy Spirit can help us find the truth. We should ask Him to guide us.

Find out what these passages say:

John 14:15-21 and 1 John 5:6

When Jesus was baptised by John, God sent a special sign to show the world that He was truly the Son of God.

What was the sign? (John 1:32-34)

Story: Galileo searches for truth

Galileo lived in Italy from 1564-1642. People in those days believed that the earth was the centre of the universe. They thought that the sun, moon and stars moved around the earth. Because the great teacher, Aristotle, had said that this was so, everyone believed it. Everyone, that is, except Galileo. He was one who wanted to find out truth for himself.

Galileo's brain couldn't rest. He had heard of a boy in Holland who had looked through a tube with spectacle glass in each end, and who found that distant objects looked much bigger. Galileo was determined to work out how this gadget worked.

He soon did. But Galileo's invention was far superior to the Dutch one. Through his telescope he could see Jupiter, which had four moons, Saturn with its rings, the spots on the Sun and the Milky Way. Now that he had seen these things for himself, he was sure that the earth moved around the sun, and not the sun around the earth.

Galileo was very excited. He now understood that God's creation was greater than people had ever realised. Enthusiastically he started telling people of his discovery. However, trouble lay ahead. Galileo was called before the Pope. "How dare you defy the teachings of Aristotle!" shouted the Pope. "You must promise not to talk or write about your theory!"

Galileo kept quiet for seventeen years, but continued working silently. Then finally, he could keep quiet no longer. He published a book of his discoveries. He was brought before the Pope again.

"Deny your theory or you will be imprisoned!" the Pope demanded.

Now quite old, and unable to bear the thought of imprisonment or torture, Galileo decided to agree that he had made some mistakes. But in his heart he knew that he had discovered the truth. Galileo lived the rest of his life quietly, working until his death in 1642. In due time, the world found out that his discoveries were true, for truth cannot be stopped by threats of imprisonment or torture. Soon others took up the teachings of Galileo, which opened people's eyes to the laws of the Creation and the glory of the stars.

From Margaret McIntyre's collection (Used by permission)

Discussion

What does this story tell us about truth?

Brainstorm

Make list of things which have lasting value, e.g. God's word, faithfulness, kindness, diligence, generosity

Game: True or false?

This is a guessing game. A player thinks of an object. Others try to guess it. The player may only reply 'true or false'. *Example:*

Guesser: "It is made of wood."

Player: "True"

Art/Craft: Make some fool's gold

Scrunch up some yellow or gold paper. Stick it on to a piece of paper or a cardboard base. Add some glitter. Then add a sign: 'All that glitters is not gold' (*old proverb.*)



God is Truth 5.3

Subtheme

True or false?

Focus

Being honest with ourselves and others

Bible references

Matthew 18:1-4 Who is the greatest in God's kingdom?

Philippians 4:8 Think about the things that are true and honourable.

Ephesians 4:25-32 Speak truthfully about others.

Songs

Whatever is Good (*Couldn't Be Finer*)

The Good Shepherd (*Sing A joyful Song*)

Introduction

Think about people who brag about their own achievements. These people will often exaggerate the truth in order to impress people. When people exaggerate they are not telling the truth about themselves. They are being dishonest.

Why do some people pretend to be better than they really are?

Act it out

Conduct a mock interview with someone who boasts and exaggerates about their achievements. Decide who this person will be, e.g. a sportsman, a pop-singer.

Discussion (Part A): *Believing the truth about ourselves*

Being honest with ourselves is simply knowing our own strengths and weaknesses. We don't pretend that we are better or worse than we really are. The Bible says that if we want to be great, then we must serve others. (Matthew 18:1-4)

We must also be truthful to others. (Ephesians 4:25)

Exaggeration is a form of dishonesty.

Discussion (Part B): *Believing the truth about others*

Should we believe everything we hear about others?

It may not be true. We should find out the truth for ourselves.

Think about this situation:

Two girls are spreading a false rumour about a certain class member. Each person who is told the rumour believes it, and immediately tells another. Soon everyone is teasing that person. Discuss the consequences. How could this have been prevented?

What should you do when someone tells you something about another person?

Game: True/false Bible quiz (*A team game*)

Prepare a list of true/false Bible statements. Write them on slips of paper and place them in a 'hat'. Form two teams. Team members take turns to select from the hat, one at a time. The team must make a joint decision as to whether the statement is true or false. The team scores a point for every correct response.

Examples:

- Joseph had twelve brothers. (F)
- Noah had three sons. (T)
- God created man on the sixth day. (T)
- God created land animals on the fifth day. (F)
- The serpent spoke to Adam in the garden. (F)
- Adam named the animals. (T)
- Abel killed Cain. (F)
- Elijah was an Old Testament king. (F)
- Jesus was born in Nazareth. (F)
- Matthew was a tax collector. (T)
- Peter, James, Phillip and John were fishermen. (F)
- Luke is the third book of the New Testament. (T)
- There were 12 Israelite tribes. (T)
- Naomi was Ruth's daughter-in-law. (F)
- Daniel was thrown into the fiery furnace for not bowing down to the statue. (F)
- The woman at the well was a Samaritan. (T)
- Paul's name was changed to Saul. (F)
- Elisha helped Naaman to believe in God and be healed. (T)
- Naaman was told to wash in the Jordan 3 times. (F)
- Elijah came first and Elisha came after him. (T)
- Satan knows God's word. (T)
- Genesis is the third book in the Bible. (F)
- Moses took the children of Israel into the Promised Land. (F)

God is Pure

Level 5 (age 9)

Subtheme

Christians should be lights to the world

Wash me and I will be whiter than snow.
Psalm 51:7



Related topics for Christian schools

Light; shadows; reflection; lighting

Other

- cleaning in the home
- water (symbol of purity)
- purity in relationships: loving and forgiving
- the fall of the perfect creation; environmental pollution
- The purity of Heaven: precious stones and metals contained in the Holy City (Revelation 21); crystals; refining of gold and silver.
- drugs and alcohol
- pollution

Character Development *(See Jesus First)*

- honesty
- goodness
- respect
- responsibility

Christian Life

- living as Jesus wants us to live
- putting into practice the words of Jesus
- having a clean heart

God is Pure 5.1

Subtheme

Christians should be lights to the world

Focus

We show that we are Christians by our actions.

Bible references

Ephesians 5:8-11 Live as children of the light

Deuteronomy 6:18 Do that which is right and good.

Galatians 5:22 Goodness is a fruit of the Spirit.

Romans 13:12 Put on the armour of light.

Philippians 4:8-9 Fill your minds with things that are true, noble, right and pure.

Songs

Holy, Holy (*Sing A Joyful Song*)

Give Me Ears (*Sing A Joyful Song*)

Lord I Want to Shine (*Couldn't Be Finer*)

More like Jesus (*Couldn't Be Finer*)

Whatever is good (*Couldn't Be Finer*)

Introduction

Light a candle. Try to think of as many uses for a candle as you can.

The Bible says that a Christian can be like a light. What does this mean?

Story 1: Mr. Biggs

There was once a school teacher named Mr. Biggs. He liked his class to be neat and tidy, but could never manage to be neat and tidy himself. He made the children tidy their work area at the end of every day. Everything had to be in place. However, Mr. Biggs's own table was piled high with a mess of papers and books. The mess was so bad that he always had trouble finding what he needed.

Mr. Biggs told the children that they must never drop rubbish in the playground. There was extra homework for anyone who did. However, when Mr. Biggs went to the park or the beach, he just left his own rubbish lying around.

Mr. Biggs told the children that they must never enter the classroom with muddy shoes. However, in his own home he didn't bother to wipe his shoes on the door mat. He just left muddy footprints on the floor for his wife to clean up.

Mr. Biggs knew the right thing to do. He believed in being neat and tidy, but just couldn't manage to be neat and tidy himself.

Some people are like Mr. Biggs because they believe in the words of the Bible. They may believe that being good and honest and pure is what God wants us to be. However, they do not live their lives the way that God wants them to live.

Living the way God wants us to live is called GOODNESS. Goodness is one of the fruits of the Spirit. We may know the right thing to do. We may even tell others what is the right thing to do, but unless we DO it we are not showing the fruit of goodness. When we truly follow the example of Jesus by doing what God want us to do, then we are like a candle which

shines brightly for everyone to see. If we say we are a Christian, then we must show it by our actions.

Bible research

Read through the fruits of the Spirit again from Galatians 5:22.

Read Philippians 4:8-9. What does God want us to do?

Read Romans 13:12. What does the Bible mean when it speaks about darkness and light?

Read Ephesians 5:10-11. How can Christians be lights to the world?

Art/Craft

1. Draw a globe of the world. Colour-in the continents and seas.
2. Draw a candle with flame. Cut it out and stick it in the centre of the globe. Colour lettering.
3. Stick globe on your window-pane or wall.

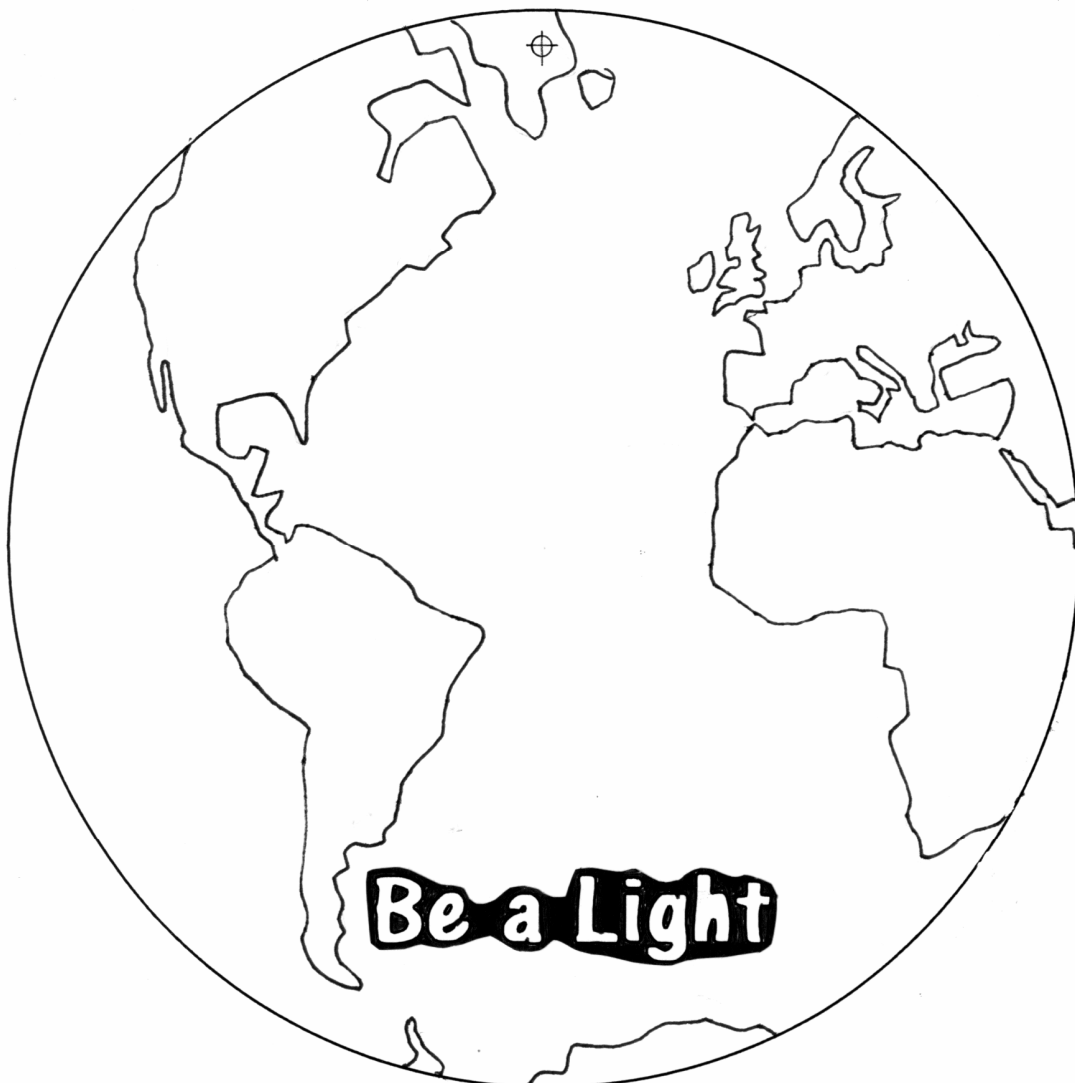

God is Pure 5.2

Subtheme

Christians should be lights to the world

Focus

Let your light shine.

Bible references

Matthew 5:13-16 Christians as salt and light.

John 8:12 Jesus, the light of the world

Songs

Lord I Want to Shine (*Couldn't Be Finer*)

I want to be More like Jesus (*Couldn't Be Finer*)

Activity 1

Give to each group member a plain cracker biscuit that is not salty.

Now give everyone another cracker and sprinkle some salt on it.

Discuss the difference in taste.

When does Mum use salt in cooking?

Why do we add salt to our food?

Read Matthew 5:13

When Jesus said that Christians are the salt of the earth, He really meant that Christians should be like a pleasant flavour. Just as people like to taste salty things, people will be interested in becoming Christians when they see God's love and joy in our lives.

Think of ways in which we can bring God's love and joy to other people. Act out some of these ideas.

Activity 2

Find a suitable container, (such as an empty can or jar), and place the container over a torch beam. Experiment with removing and replacing the cover. Observe the difference. This will work better in a darkened room.

Read Matthew 13:14-16

Discuss ways in which Christians can make their light shine.

Art/Craft

Make a 2D candle to stick on your window. Decorate with markers.

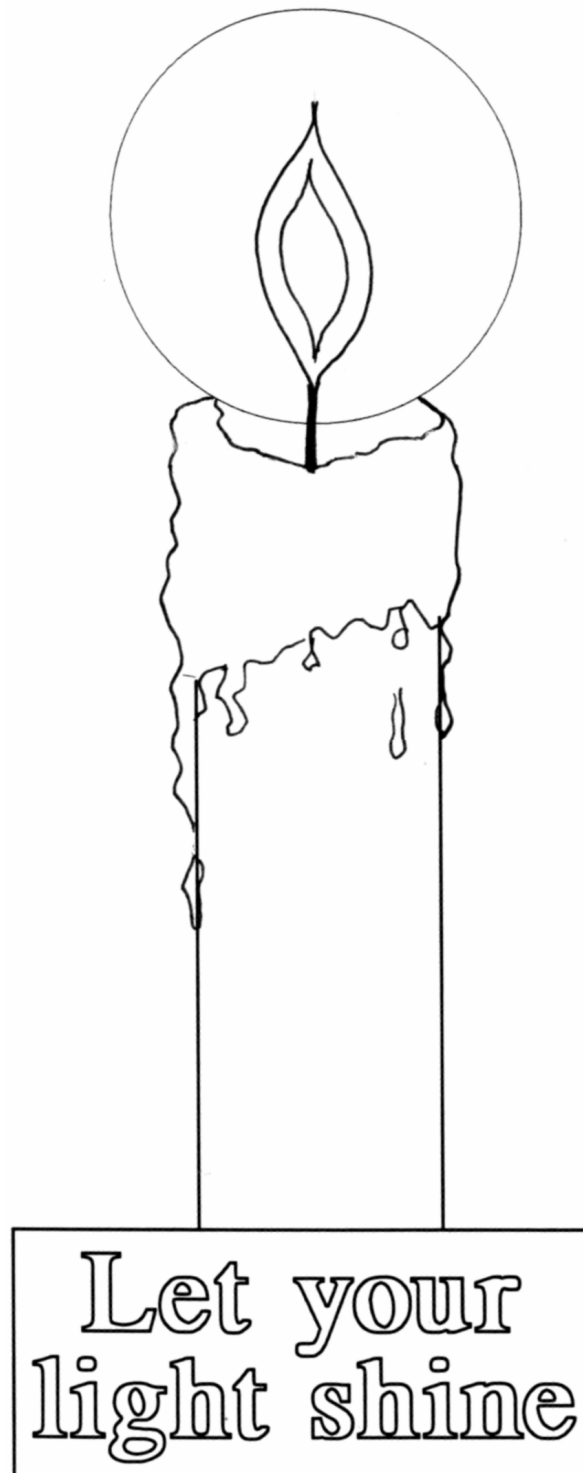

God is Pure 5.3

Subtheme

Christians should be lights to the world

Focus

Jesus wants us to live lives that are pure.

Bible reference

John 5:14 You are my friends if you do what I command you.

Galatians 5:22 The fruit of the Spirit

Matthew 7:15-20 A tree is known by its fruit.

1 John 1:5-7 Walk in the light as He is in the light.

1 John 2:28-29 Everyone who does what is right is of God.

Songs

I want to Be More like Jesus (*Couldn't Be Finer*)

Whatever is Good (*Couldn't Be Finer*)

Lord I Want to Shine (*Couldn't Be Finer*)

Give Me Ears (*Sing A Joyful Song*)

Introduction

Revise the nine fruits of the Spirit.

Act it out

Each person in the group is given one fruit of the Spirit to mime. The others guess which fruit it is.

Bible research

Read 1 John 2:29. If we say we are a Christian, how should we act?

Read 1 John 1:5-7. What does it mean to walk in the light?

Walking in the light can mean that we think before we act. If something goes wrong, do we act in a 'typical' way? Do we do or say the first thing that comes into our head? Or do we stop and think about how Jesus would handle the situation?

Discussion: How should we react?

Here are some examples of things that could happen in every day life. We could react in a good way or in a bad way. Think about how we can show the fruits of the Spirit in these situations. Try to make up your own situations as well.

Simon has spent hours on building something. Little sister comes and pulls it apart while Simon is out of the room. How should Simon react?

a) with anger; wanting to pay back; throwing a tantrum

b) forgiving little sister; exercising self-control; accepting the situation without getting angry

A new girl has come into the class. She is very shy and doesn't look as if she would be much fun to play with. How should the girls in the class react?

a) ignore her and play with old friends

b) make friends with her and include her in your games

A shop keeper gives Laura too much change. How should Laura react?

a) Too bad for the shop keeper. I'm keeping the extra money.

b) I'd better take back the extra change.

God is Patient

Level 5 (age 9)

Subtheme

The Holy Spirit produces patience and self-control

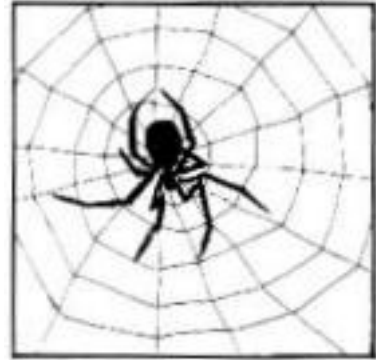

Be patient with everyone. 1 Thessalonians 5:14 (GNB)

Integrated Topics for Christian education

Occupations requiring patience: e.g. surveying; architecture; farming

Other

- waiting for seeds to grow
- measuring time
- listening to others patiently
- listening, sound and the ear
- patience with people
- patience with the elderly or disabled
- tolerance
- patience displayed by animal home-builders e.g. spiders
- lifestyle 100 years ago: patience in doing tasks manually.
- lifestyle of pioneers and early settlers
- development of technology

Character Development *(See Jesus First)*

- patience
- diligence
- self-control

Christian Life

- being patient with others
- having self-control
- waiting for God to answer prayer

God is Patient 5.1

Subtheme

The Holy Spirit produces patience and self-control

Focus

Having patience with others and controlling anger.

Bible references

Galatians 5:22 The fruit of the Spirit.

James 1:19 Be slow to anger.

Proverbs 19:11 If you are sensible you will control your temper. (GNB)

Ephesians 4:32 Be kind to one another.

Luke 22:47-51 Peter acted in anger. Jesus, in contrast, showed patience with His enemies.

Matthew 5:44 Love your enemies.

Job The patience of Job.

Songs

Waiting Patiently (*All Creation Sings*)

Jigsaws (*Sing A Joyful Song*)

More like Jesus (*Couldn't Be Finer*)

Introduction: A patience game

Each person in the group is given a square of paper. The aim is to tear the paper in a continuous strip, and to see who can make the longest 'snake'.

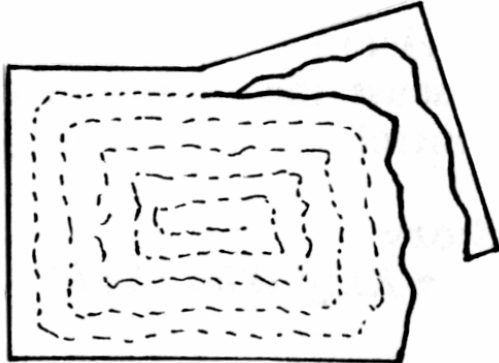

Discussion

Which of these would take the most patience for you?

- putting away all the dishes
- threading a needle
- peeling a kilo of potatoes

In these examples we need patience to things that may be difficult or boring. We also need patience to do things we find difficult. We should not give up until we have finished. However, sometimes we need a different sort of patience. That is, patience with people. We may find some people difficult to get on with. Maybe we feel like shouting or screaming, or even hitting. These are the times when we can show patience towards people. Remaining calm, instead of acting in an angry way is showing self-control.

Act it out

Think of situations that may require self-control. Work in pairs to show the best reaction to the situation.

EXAMPLE

Joshua has spent hours on his model plane. His friend Chris, takes the plane without asking and tries it out. The plane crashes. One wing is damaged. Joshua sees what has happened. He is very upset, but tells Chris that it's OK. He invites Chris to help him mend it.

Bible research

Find out what the Bible says about patience and self-control:

Galatians 5:22

Ephesians 4:32

James 1:9

Story 1: Peter shows his anger

Jesus and his friends were praying in the garden. It was the evening that Jesus would be arrested. Judas had made plans with the chief priests. For carrying out the plan he would receive thirty pieces of silver.

A crowd of men entered the garden. The leader of the group was Judas. Judas walked up to Jesus and kissed Him. This was part of the plan. Judas had arranged to kiss Jesus as a sign, so that the priests would know which man to arrest.

Jesus looked at Judas.

"Are you trying to sell me with a kiss?" He asked.

"Are you Jesus of Nazareth?" the chief priest asked Jesus.

"I am." said Jesus calmly.

Peter was extremely angry. Instead of acting calmly as Jesus did, he drew his sword. He lashed out with the sword and cut off the right ear of the chief priest's servant.

"Put away your sword, Peter," said Jesus.

Jesus could have reacted by fighting too. He had good reason to fight. He was arrested simply for saying that He was the Son of God. He could have acted angrily toward Judas for betraying Him. Judas had once been one of Jesus' best friends.

In all of this, Jesus managed to live by the words He had spoken:

"Love your enemies," He had told His disciples.

Jesus spoke to Peter.

"I could stop these men if I wanted to," He said. "I could pray to my Father and He would send Me a thousand angels to fight for Me."

But Jesus didn't want to fight with words or actions. Instead, He touched the servant's ear and healed him. Then Jesus was led away by the chief priests and Pharisees.

Discussion

When someone does something against us, we can become angry and hurt the other person physically, or with our tongue. Jesus wants us to control both of these reactions. Read Matthew 5:39 and James 3:8-11.

Sometimes, when bad things happen to them, people become angry with God. Really it's not God's fault at all. Here is a story about someone who went through bad times, but continued to trust God.

Story 2: The patience of Job

Job was one of God's faithful servants. Satan knew this, and decided he would cause trouble for Job. His plan was to bring so much trouble into his life, that Job would become angry with God and turn away from Him.

What did Satan do to Job? (Job 2:7-8)

Did Job become angry and turn away from God? (Job 2:10)

No matter how much trouble Satan brought along, Job was patient. He continued to trust God. Finally Satan stopped bothering Job, because he could see that Job was not going to give up trusting in God. God rewarded Job for being faithful. You can read the end of the story from Job 42:10-16.

Discussion

What should people do when they have trouble in their life?

Game: Pick-up-sticks

Take a packet of straws. Bundle them together. Allow them to fall at random. Each player takes turns to pick up as many straws as possible, without disturbing the other straws. If other straws are moved, then the next player takes his/her turn. This game takes patience!

God is Patient 5.2

Subtheme

The Holy Spirit produces patience and self-control

Focus

Self-control: anger, jealousy and greed.

Bible references

1 Samuel 17; 1 Samuel 26 King Saul's uncontrolled anger toward David
Ecclesiastes 7:9 Keep your temper under control. It is foolish to harbour a grudge. (GNB)
Ephesians 4:26 Do not let your anger lead you into sin. (GNB)
Galatians 5:20 Envy, jealousy and anger are opposite to the fruit of the Spirit.
Hebrews 13:5 Warning against greed - be satisfied with what you have!

Songs

Waiting Patiently (*All Creation Sings*)
More like Jesus (*Sing A Joyful Song*)

Revision

Discuss the meanings of patience and self-control.

Story: The king who could not control his anger

King Saul had been a good king. He had helped the Israelites defeat their enemies. People sang songs about his victories. However, now the people were paying more attention to David than Saul. David was now the brave hero who helped the Israelites win their battles. David had killed the giant, Goliath, completely unarmed. It was now David who the people sang about.

Jealousy grew in King Saul's heart. It caused him to change from a noble, upright king, to a king who could not control his anger.

David had played music for King Saul, on his lyre. However King Saul didn't like David's music any more. One day, as David sat playing, King Saul suddenly took his spear and threw it at David. David dodged and the spear went into the wall.

From this point on, David knew that he must hide from the king. King Saul remained David's enemy for many years, until Saul finally died, and David became the new king.

Discussion

King Saul had two problems:

He was jealous of David who was so popular with the people.

He became angry.

How do you think he should have handled these two problems?

Look at the different problems which arise when people do not control their anger and greed.

1. Think about anger.

We can act quickly, without thinking, and hurt someone physically. We can also hurt people with our tongue.

Find out what the Bible says about controlling anger:

Ephesians 4:6 and Ecclesiastes 7:9

2. Think about greed.

Being greedy could mean:

- Eating too much at a party.
- Eating too many sweets.
- Spending all your money on things you don't need.
- Wanting all the things your friends have.
- What else?

When you are greedy, others could miss out.

Puppet Plays: Self-control

1. The magnifying glass

Billy: Can I have a go of your new magnifying glass, Betty?

Betty: Sure Billy, but be careful with it.

Billy: Thanks Betty.

(Billy is not careful, drops the magnifying glass and breaks it.)

Betty: Oh look what you've done Billy! You've broken it, you clumsy thing!

(Betty screams, shouts and hits Billy.)

2. Spending

Betty: How much money have you got in your money box Billy?

Billy: About \$2 I think.

Betty: I've got \$1.50. Why don't we go and spend our money!

Billy: Well, I was actually saving up for Mum's birthday present.

Betty: Come on, Billy! You can get some more money before your Mum's birthday.

Billy: Well, OK then.

(Billy and Betty appear with a large plastic bag full of sweets.)

Betty: Do you think we should eat them all now, or save some for later?

Billy: Let's eat them all now.

Discussion

1. Why did Betty need self-control in scene 1?
2. Why did both children need self-control in scene 2?
3. Sometimes children want everything they see advertised on T.V., or when they go shopping they want to buy everything in the shop windows or in the advertising catalogues they come across. What is wrong with wanting every new and exciting thing we see?
4. What does the Bible say about this? (Hebrews 13:5)
5. We need self-control when we watch T.V. advertisements, or look at advertising catalogues. Instead of wanting everything, we can have self-control by th_____ God for all He has given us.
6. What does the Bible say about self-control? (Hebrews 13:5)

Wanting the things that others have, is called envy. Another word for it is jealousy. It doesn't just concern wanting things like toys and clothes. We can be jealous of another person because they can do something better than we can. King Saul was jealous because he was not as popular as David was. We can control envy by thanking God for all He has given us, and for making us the way we are.

Activity

Sit in a circle and make up a continuous story about a boy, or a girl, or a family, who wanted every new and exciting thing. The story grows as each person adds a sentence.

Game

1. Cut out 11 large paper squares.
2. Write the 11 letters of the word 'self control', one letter on each square.
3. Tape the paper squares to the floor at various points. Now get a bean bag or ball and set up a game where the children have to take turns to throw the bean bag at a letter. This can be a team game.
4. Draw a line that the thrower must stand on while they are throwing.
5. Scoring: 'S' scores 11 points; 'E' scores 10 points and so on. The player or team scoring the highest total wins.

Aesop's fable: The greedy dog

Once there was a dog that was given a juicy bone for his dinner. He took the bone and ran off with it, in search of a special hiding place. He wanted to find a place where no other dog would take it.

On his way to the special hiding place he crossed over a bridge. As he was running across the bridge he caught sight of another dog in the water. He stopped at once. He noticed that the other dog had a bone even bigger than his own! The greedy dog growled at the other dog, dropped his own bone and jumped into the water, thinking that he could grab hold of the other dog's bone.

Splash! Into the water he fell. There was no dog there after all. He had only been looking at his reflection. As for its own bone, it had sunk to the bottom of the river. The greedy dog went home sadly, with no bone at all.

What kind of bone did the dog have?

Why did the dog want to hide his bone?

What is a reflection?

Who was the other dog in the water?

What would you say to the dog at the end of the story?

Aesop's fable: The golden eggs

One day a farmer went to the market to buy a goose. When he went out to his barn the next morning he found that the goose had laid a golden egg. He called his wife at once. They were both amazed.

"I wonder if the goose will lay another egg tomorrow?" said the farmer's wife.

Sure enough they found another golden egg the next day, and the next, and the next.

"If we save up all the golden eggs we will be rich enough to buy whatever we want," said the farmer's wife, "but with only one egg every day it will take too long. Why don't we kill the goose, cut it open and take out all the golden eggs. Then we will be rich at once."

"What a good idea," said the farmer. He killed the goose and cut her open, but sad to say, there were no golden eggs inside. Now all they had was one ordinary dead goose! How sorry they were for being so greedy.

Questions:

1. What would you say to the farmer and his wife at the end of the story?
2. Who said this?
 - a) "If we save up all the golden eggs we will be rich enough to buy whatever we want."
 - b) "Why don't we kill the goose and take out all the eggs."
 - c) "What a good idea"
3. Complete the sentence: _____
_____, *but sad to say there were no golden eggs inside.*

God is patient

Self-control is not always about controlling our anger. Sometimes it's about controlling our desire to want things. Wanting too many things is being greedy. If we are patient and content, then we will not want everything we see.

Being greedy could mean:

- E _____ too much.
- S _____ all your money on things you don't need.
- W _____ all the things your friends have.
- Others could _____ out.

Missing words: wanting miss eating spending

How can I have more self-control when I see things I want?

I can remember that Jesus gives me the things I really need.

I must decide which things I really need.

I can be happy with the things I have.

I can be patient, and wait for Mum and Dad to buy me things at the right time.

God is a Servant

Level 5 (age 9)

Subtheme

Jesus, the faithful servant

Let love cause you to serve one another. Galatians 5:13 (GNB)



Integrated topics for Christian Education

Serving through occupations

Other

- serving in the home
- people who serve in the community
- medical profession
- animals that serve man
- community insects: a social system built on serving
- communications
- serving with time and talents
- biographies of people who have served
- ways in which technology serves us; use of technology in spreading the gospel
- pioneers and explorers who sacrificed and endured
- missionaries

Character Development *(See Jesus First)*

- helpfulness
- humility
- sacrifice

Christian Life

- serving God and others with humility
- giving up time and energy to help others

God is a Servant 5.1

Subtheme

Jesus, the faithful servant

Focus

Faithfulness in friendship

Bible references

John 17:1-26 Jesus was faithful to His friends. He prayed for them; He provided for them.

Luke 10:4; Matthew 17:27; John 21:15 Jesus loved and forgave His friends.

John 13:4-5 Jesus washed the disciples' feet.

Luke 12:35-47

The faithful servant is the one who knows what his master wants, and does it.

Hebrews 2:17 Jesus, the faithful servant

1 Samuel 18, 19, 20 The faithful friendship between David and Jonathan.

Proverbs 17:17 A friend loves at all times

Songs

A Servant for Jesus (*All Creation Sings*)

What Can I Give? (*Sing A Joyful Song*)

Jesus Take My Hands (*Sing A Joyful Song*)

Lord I Want to Shine (*Couldn't Be Finer*)

Welcome Jesus (*Couldn't Be Finer*)

Introduction

Revise the meaning of "faithfulness".

How would you show faithfulness to your best friend?

How can you serve your best friend?

Story 1: David and Jonathan

King Saul had a son whose name was Jonathan. Jonathan was a brave young soldier. From the moment he met David he loved him. Jonathan admired David's bravery and strong faith in God. Jonathan, being a prince, had fine clothes. Jonathan was a poor shepherd boy and had no fine clothes. Jonathan gave David his fine belt and coat, as well as his sword and bow and arrows. David and Jonathan were like brothers. They promised to be faithful friends as long as they lived.

When King Saul became jealous of David, and could not control his anger, David's life was in danger. Both David and Jonathan knew that King Saul might kill David. Jonathan helped to protect David by warning him of the king's anger. Jonathan thought up a special secret sign to tell David that the king was angry, and that David must hide. This was the sign: Jonathan said he would shoot some arrows in a field, near a certain rock. David must hide behind the rock and watch. Jonathan would take a boy with him to the field to fetch the arrows. If Jonathan shot the arrows to land in front of the boy, then David would know that everything was safe, but if he shot the arrows beyond the boy, the David would know that it would be dangerous to come out from hiding.

At the palace, things were not good. "Why are you friends with David!" Saul shouted at Jonathan. Jonathan knew that he must warn David. The next morning he went to the field with a boy as arranged. He warned David with the special secret sign. David and Jonathan were sad to part. Jonathan went back to the king's palace, while David hurried off to hide in

a cave. Although they could no longer be together, they always remembered each other as best friends.

Discussion

How was Jonathan faithful to David?
Did Jonathan serve David?

Brainstorm

Jesus had twelve best friends and He was faithful to them all. How did He faithfully serve His best friends?

Write ideas on a large piece of paper. Discuss each idea. Some suggestions could be...

He LOVED them, PROVIDED & PRAYED for them

He TAUGHT them about God

He WASHED their feet

He always did what He said He would do

Jesus continued to be faithful to His friends even after He returned to Heaven. He promised to send the Holy Spirit to help them. When the Holy Spirit came He comforted them and gave them the ability to do great miracles.

Jesus promises that He will be our best friend too if we invite Him into our life. He will be just as faithful to us as He was to His disciples.

Activity

Think of a way in which you can serve your best friend this week.

Make a card or gift for your friend with the inscription: A friend loves at all times. Proverbs 17:17

God is a Servant 5.2

Subtheme

Jesus, the faithful servant

Focus

Serving Jesus faithfully

Bible references

Acts 1-2 The disciples receive power to work for Jesus.

Acts 4:13-22 The disciples were warned not to speak about Jesus.

Acts 7 Stephen was faithful.

Acts 8:1-4 The disciples continued to be faithful in the face of danger.

Luke 12:35-47 Be faithful in doing what Jesus wants us to do.

Game: Masters and Servants

Work in pairs. For each pair, one acts as the 'master'; the other as the 'servant'. The master must give the servant a series of instructions to be followed. The servant must follow the instructions faithfully, without forgetting any steps. (You may prefer to limit the number of steps.)

The group may like to draw up a list of suitable instructions first.

EXAMPLES:

1. Walk to the table.
2. Take ... paces backwards.
3. Touch your toes ... times.

Discussion

In the game you needed to listen carefully in order to remember what the master wanted you to do. If we are to understand what Jesus wants us to do, then we must also listen carefully.

What does 'listening to Jesus' really mean?

A master wants his servants to know the right things to do, and to do them well. This is being faithful. Read what Jesus said about being a faithful servant: Luke 12:43.

What does Jesus expect us to do, as faithful servants?

Just as Jesus was faithful to His twelve best friends, the friends, (except for one), were faithful to Jesus.

Story: The faithful friends

Imagine that you are one of the eleven faithful friends. You are feeling sad because Jesus has gone to be with his Heavenly Father. Jesus has told you to tell others about Him, and to heal people in his name, but you don't know how you can possibly do these things. Jesus promised that the Holy Spirit would come and give you power. "How would this happen? What is the Holy Spirit like?" you are thinking.

Then, as you are waiting and praying with the other disciples, it happens. There is a mighty rushing wind. The sound is almost deafening. Then there appear to be little flames of fire on everyone's head, including your own! What is happening? No, your hair doesn't catch alight. It's not that kind of fire. You feel so happy, and just full of God's love.

The wind and fire leave, but you feel different. You are no longer sad that Jesus has gone. You can feel Him right there with you all the time, even though you can't see Him. You are no longer afraid. You want to go and tell others about Jesus. You want to pray for people and help them just like Jesus did. Your friends feel the same way.

All the friends of Jesus are now speaking about Him in the streets and market places, healing people and seeing other miracles. People are being healed and set free from their problems. Thousands of people are becoming followers of Jesus.

However it is not long before there is trouble. It's the religious leaders again. They do not like everyone following this new religion called Christianity. Peter and John have been told not to speak or teach at all in the name of Jesus. But Peter and John cannot keep quiet. "We must speak about what we have seen and heard," they say.

One of the followers called Stephen speaks very boldly about Jesus and even puts down the teachings of the religious leaders. The older religious leaders talk amongst themselves. "This man is always saying things against the old way of Moses. He talks about a new way... that Jesus can forgive sins and there is no need to offer sacrifices any more! We don't like the new way. Let's get rid of him!" they say.

Stephen does not stop talking about Jesus even though he knows what the religious leaders are thinking. It is not long before the religious leaders decide to get rid of Stephen.

Read Acts 8:2-4.

Now all the followers of Jesus are faced with a choice. It is obvious that following Jesus from now on will be very difficult, and very dangerous. If you want to stay out of trouble, then you will have to give up following Jesus. Or, you could choose to be faithful and continue speaking about what you know to be true.

With the other followers, you decide that you will continue to speak about what you have seen and heard. You continue to meet together to pray and sing and learn about God's kingdom, but you now have to do it in secret. You often meet in underground caves so that the Roman soldiers will not find you. On the walls of the caves there appears the special secret sign that shows you are Christians. It is the sign of the fish.

Discussion

Why do you think the early Christians chose a fish for their secret sign?

The early followers did not give up following Jesus, even when it was difficult. When might it be difficult for us to be Christians today?

What can we do when things get difficult?

Act it out

Make up endings to these sketches, to show how a Christian might react in these situations.

Person A is not a Christian.

Person B is a Christian.

Sketch 1

Person A is handing out sweets. He/she boasts about stealing the sweets from the milk bar down the road.

Person B is offered a sweet.

Sketch 2

All the children are having great fun teasing a new boy/girl. They decide to play a mean trick on him/her.

Person A asks person B to join in.

Puzzle

Key:

a=#

e=*

i=?

o=\$

u=^

Decode the following sentence:

W* c#nn\$t st\$p sp*#k?ng #b\$^t wh#t w* h#v* s**n #nd h*#rd. #cts f\$^r v*rs* tw*nty.

Art/Craft

Make fish stencils from cardboard. Use the stencils to make cards.

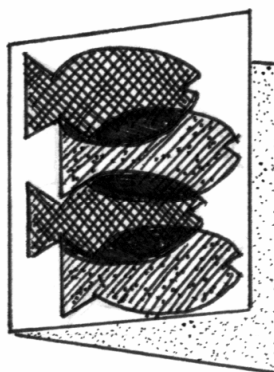
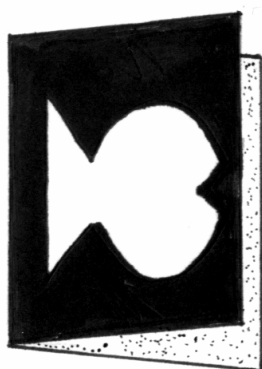

God is a Servant 5.3

Subtheme

Jesus, the faithful servant

Focus

Be faithful in using your gifts for God.

Bible references

Luke 16:10 Be faithful in little things.

Matthew 25:14-29 Parable of the talents

Songs

A Servant for Jesus (*All Creation Sings*)

What Can I Give/ Jesus Take my Hands (Sing A Joyful Song)

Lord I Want to Shine (*Couldn't Be Finer*)

Introduction

Draw up a chart to show gifts and talents of each person in the group.

EXAMPLE: GOD HAS GIVEN US THESE GIFTS

Sharon.....playing piano

David.....drawing

Natalie.....singing

James.....swimming

God has given each person not just one talent, but many. If we are to be faithful servants, we should ask God how we can use our gifts and talents for Him. Our whole life can be a gift to Him.

Story 1: John Flynn

John Flynn believed that God wanted him to become a minister and go the Centre of Australia. It was a time when much of the outback was being opened up for sheep and cattle stations. People had to travel hundreds of miles for medical help. There were also hundreds of people in the outback who had not heard the Gospel, because there was no one to tell it.

John began working in the outback of South Australia in 1911. He travelled over the hot, sandy country in a horse and buggy. He often had to act as doctor, dentist, school teacher as well as preacher.

John knew that people in remote places must have better access to medical centres, or many would die. In his time there were 15 inland hospitals set up, where station people could receive medical help more quickly.

However this was not the complete answer. One day, John was visiting Adelaide and saw an aeroplane.

"That's what we need," he said.

John Flynn now ran a mission, and with the help of others worked towards establishing a Flying Doctor service, so that doctors could fly to visit patients, and patients could be flown to hospital. One of the problems in the outback was the sending of messages. With the help of his friend Alfred Traegar, John managed to develop a pedal wireless, which could send and receive messages, if the people worked the pedals as they used it.

The radio receiver was not just used by people in an emergency, but enabled lonely, isolated people talk with others every day.

Discussion

1. Why did John want to go to the outback?
2. How did he travel in the early days?
3. How did he *want* to travel?
4. How could an aeroplane help his work?
5. What is the name of the special service he began?
6. How did the people of the outback get messages to John?
7. What were some of the gifts and talents John may have had as a young boy?
8. Why do you think John was so successful?

Story 2: The Three Servants

Read the story from Matthew 25:14-29

Discussion

This story is a parable told by Jesus. Jesus meant the story to have another meaning. It is not just a story about servants receiving bags of money. The hidden meaning is to do with God's servants receiving gifts from Him. The servants received different amounts of money. We cannot measure God's gifts to people in 'amounts', but we can say that God gives people different KINDS of gifts.

To some He gives a gift of music. To others He gives the gift of caring. There are many different ways in which we can serve Him.

Just as the men in the story had to use their money to earn money, Christians should serve God with the talents God has given them. God used John Flynn's talents and multiplied them, so that many more people were reached.

Look again at the talents within the group. How could these be used for God?

Game: Charades

Each person must mime a talent. Others in the group try to guess what it is.

Activity

Arrange a group visit to a hospital or retirement village. Plan ways of using talents within the group to bring happiness to others, e.g. musical items, dance, showing friendship, preparing flowers, gifts, cards.

Interview

Invite a visitor... someone who has used their talents for God, e.g. Christian doctor, nurse or missionary. Conduct an interview with the visitor or ask them to give a short talk about their work.

God is Life

Level 5 (age 9)

Subtheme

God is the joy of life

*No one can see the kingdom of God unless he is born again.
John 3:3 (GNB)*



Integrated Topics for Christian Education

- Joy in celebrations: cultural festivals and special occasions.
- Having fun together; traditional games from around the world.
- Use of colour to bring joy; making of colourful kites and balloons; science experiments related to these.

Other

- plant life; ecosystems
- requirements for life-support: air; food; water
- animal life
- the cycle of life from birth to old age
- requirements for life: air, water
- desert survival

Character Development *(See Jesus First)*

- joy
- enthusiasm

Christian Life

- receiving God's gift of eternal life
- accepting Jesus as Lord and Saviour
- knowing the joy that Jesus gives

God is Life 5.1

Subtheme

God is the joy of life

Focus

Celebration and praise to the Creator.

Bible references

Psalms 95:1-5 Sing to the Lord joyfully.

Psalms 100 Make a joyful noise.

Psalms 147:1 & 7 It is good to praise God.

Psalms 66:1; Psalm 148 The whole creation praises Him.

Psalms 149; Psalm 150 Praise the Lord with instruments

Luke 19:37-40 The people praised Jesus as He entered Jerusalem.

Songs

All Creation Sings (*All Creation Sings*)

He is Alive (*All Creation Sings*)

Let's Celebrate (*Sing A Joyful song*)

The Dancing Song (*Sing A Joyful song*)

Introduction

Prepare for a praise party by decorating a 'praise cake'.

This can be a sponge slab. Ice the slab and mark out the letters 'PRAISE JESUS' using 'smarties' or sultanas.

Discussion: What is praise?

We praise someone when they do something well. For example, we clap when someone performs well at a concert. It shows that we appreciate their performance. Imagine a concert with no applause. How would the performer feel?

We need to praise God too, for the great things He has done. It's more than just saying "thanks God" for sending rain, or for giving us food. It's saying, "God, You are wonderful! Everything You have made is beautiful. Lord, You are more powerful than anyone in the whole universe. God, You're great!" Make up a 'praise prayer', telling God how great He is.

Praise party

Blow up balloons and write messages on them to God...

EXAMPLES:

God, You're great!

God, You are mighty!

Everything You make is beautiful, God!

We praise You God for making us!

Decorate the room with the balloons. Prepare for a musical praise time by making flags and streamers on sticks. Find or make percussion instruments. Play percussion instruments or wave flags and streamers during a musical praise time. (Avoid having all instruments playing at once!) Read verses of praise from Psalms between songs.

At the end of the session, eat the 'praise cake'.

God is Life 5.2

Subtheme

God is the joy of life

Focus

Giving your joy to others

Bible references

Galatians 5:22 Joy is a fruit of the Spirit.

Acts 3:1-10 Peter and John gave joy to the lame man when they prayed and God healed him.

Acts 16:23-26 Paul and Silas sang songs of praise, even in jail.

Philippians 4:4 Rejoice in the Lord always.

Songs

He is Alive (*All Creation Sings*)

The Dancing Song (*Sing A Joyful Song*)

Let's Celebrate (*Sing A Joyful Song*)

Puppet play: Betty's Problem

Billy: What's wrong, Betty?

Betty: I'm not feeling very happy today.

Billy: Why not?

Betty: The boy from next door was rude to me, then he squirted me with his water pistol, and as I was running inside to get away from him I slipped over and got my dress all muddy. Then I went to wash it and spilt the washing powder all over the floor.

Billy: Don't worry Betty. I'll help you clean up the mess... and never mind about that boy next door. Hey Betty! How would you like to come over to my place after we've cleaned up. We can watch T.V. and have some ice-cream... and I'll let you have a lend of my favourite racing car.

Betty: Thanks Billy. You're a real friend.

Discussion

What was Betty's problem?

How did Billy cheer her up?

In being kind to Betty, and helping her to feel happier, Billy was giving JOY. Giving away joy is like giving away a smile. We don't lose it by giving it away.

Joy is one of the fruits of the Spirit. Add this to the fruit tree.

Satan can make us lose our joy. He doesn't like to see Christians happy so tries to steal our joy. However, God has given us a special weapon to fight this kind of attack from Satan. It is the weapon of PRAISE. When we are having a hard time, it helps to praise God for who He is. This is what Paul and Silas did when they were having a hard time in jail.

Story 1: Paul and Silas

Paul and Silas were in jail. They had been thrown in jail for speaking about Jesus. You would think they'd be terribly unhappy. They had their feet pinned down between large blocks of wood. However, in spite of this, they still had joy. They refused to allow Satan to steal their joy.

Find out how they kept their joy. Read Acts 16:25. While they were praising God, a miracle happened. Find out how God set them free. (verse 26)

Story 2: Joy for a crippled man

Another two of Jesus' followers, Peter and John, shared the joy of Jesus with others. They did this by telling others about Him and praying for the sick.

Read about the joy they gave to a crippled man. Acts 3:1-10 (International Children's Bible). How did the crippled man show his joy? (verse 8)

Puzzle

Unjumble these words to make a Bible message. Check your answer by looking up Philippians 4:4.

OF JOY ALWAYS THE OF BE LORD FULL THE

Brainstorm

Think of ways in which you can give away joy to others. Write suggestions on a large sheet of paper.

Art/Craft - activity 1

Make a card for yourself to remind you about giving away joy. Write the verse from Philippians 4:4 inside.

Art/Craft - activity 2

Have fun with things that move with air.

Make a wind-sock for your porch or verandah.

Steps:

1. Take a piece of A4 paper (21 x 30 cm).
2. Make a colourful design on your paper and add a message in colourful letters.
3. Reinforce top (longer side) with masking tape as shown.
4. Make paper into a cylinder by gluing together the two shorter sides.
5. Using both glue and staples, attach ribbon to the top for suspending the wind-sock. Attach coloured streamers to the bottom.

Make a colourful kite and a whirly-twirly.

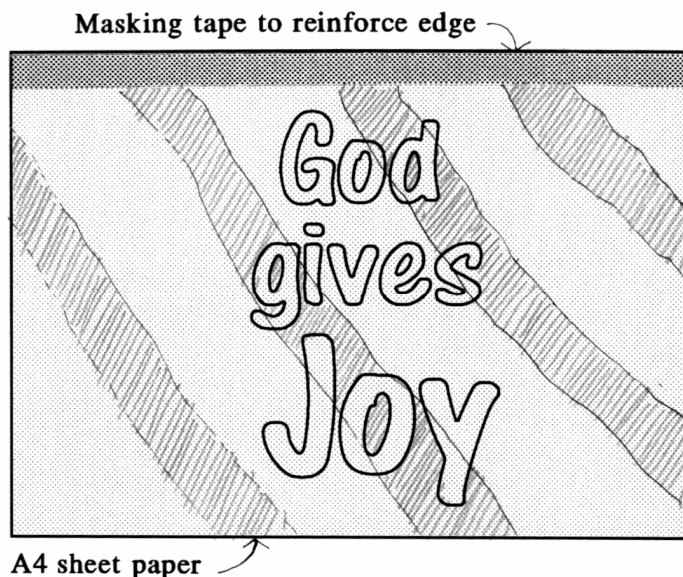

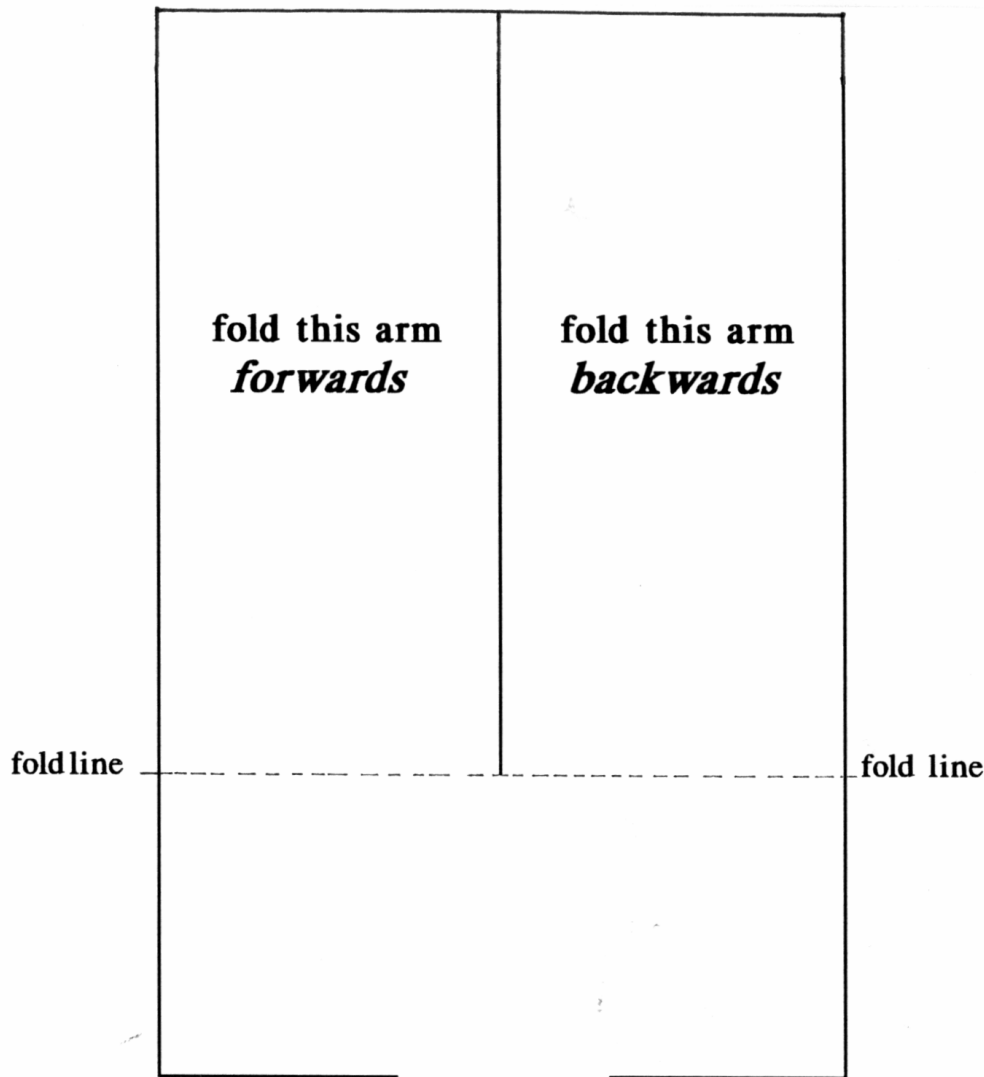

Cut out on all solid lines.

Whirly- twirly

push on paper-clip
to give weight to 'nose'
of whirly-twirly

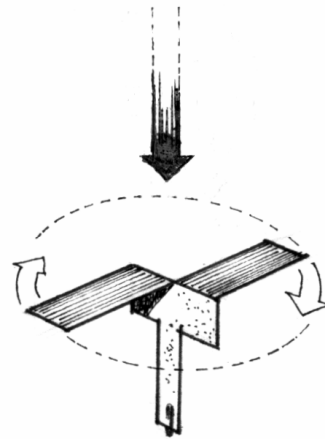
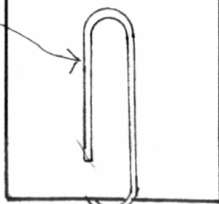

finished
whirly-twirly

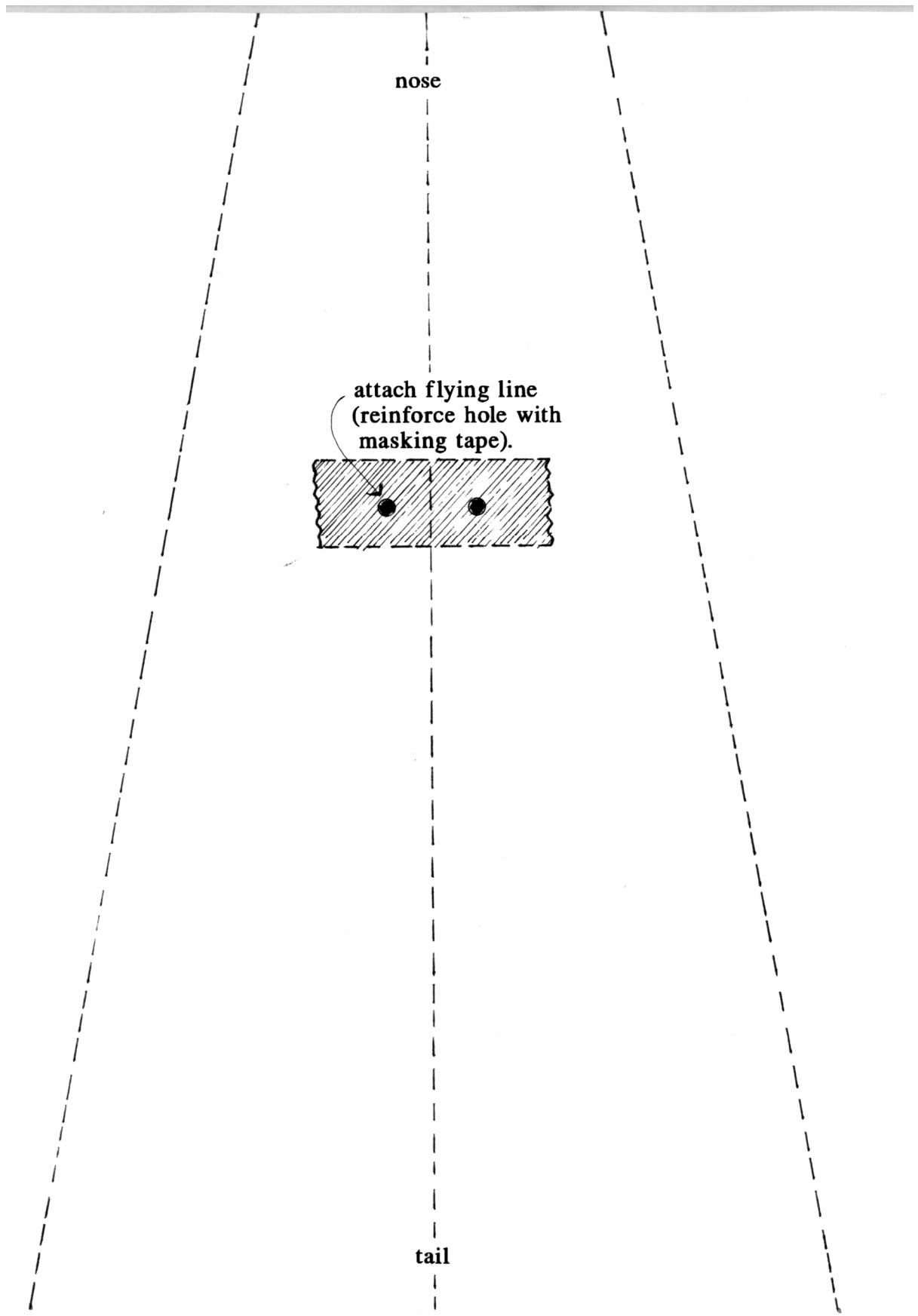

God is Provider

Level 5 (age 9)

Subtheme

God is a faithful provider

I have provided all kinds of grains and all kinds of fruits for you to eat. Genesis 1:29 (GNB)



Integrated Topics for Christian Education

Animal farming

Other

- Food: buying food; preparing food; kitchen chemistry; heat
- plants
- forestry
- fishing industry
- third world food shortage
- technology
- rainforests; ecosystems
- fibres and fabrics
- natural materials

Character Development *(See Jesus First)*

- trust
- faith
- thankfulness
- generosity

Christian Life

- trusting God as Father
- thanking God for His provision

God is Provider 5.1

Subtheme

God is a faithful provider

Focus

We can always depend on Him.

Bible references

Exodus 15:22-27 Provision of water in the desert. Bitter water made sweet.

Exodus 16 Provision of manna and quails.

Job 36:26-31 The greatness of God; His faithfulness in providing through the creation.

Songs

God is a Provider (*All Creation Sings*)

The Journey (*Sing A Joyful Song*)

What a Mighty God (*All Creation Sings*)

Thank You for All the Good Things (*Couldn't Be Finer*)

Thank You Lord for This Fine Day (*Couldn't Be Finer*)

Story 1: Food and water in the desert

God's people were travelling through the desert. It was only three days after crossing the Red Sea. They had been travelling three days with no water. They would have to find water soon or they would die. Moses prayed to God. They came to a place called Marah. There was water here but it was stagnant and smelly. If they drank this water they would probably die anyway.

- Find out what God did. (Exodus 15:25a)

The Israelites had just learned their first lesson. They must trust God even when things seem desperate. They now understood a little more about God's faithfulness. God proved His faithfulness again six weeks later. This time the people were desperately hungry. They forgot about God's faithfulness in the previous water crisis. They started complaining.

- What did they say? (Exodus 16:2-3)
- What did God tell Moses? (verses 4-5)

God provided food for them just as He had promised.

- What food did He provide? (verses 13-16)

Each person was instructed to gather as much as they needed. Some were greedy and disobedient and wanted to gather extra, "just in case God didn't provide tomorrow," they thought.

- What happened to their food? (verse 19)

God also told them that He would not provide on the seventh day as this was a day of rest. On the sixth day they were permitted to gather extra and save it for the next day. Read about this in verses 22-26.

Some foolish people did not believe God.

- What did they do? (verses 27-30)

God has promised to provide for the whole of His creation. Read Job 36:26-31.

Some people in certain parts of the world have too much food, while in other places people have too little. God expects people with too much to share with those who have too little. That is another way God provides...through people!

God can also provide through miracles, just as He did with the Israelites. Here is a story about God's miraculous provision for someone who trusted God.

Story 2: Gladys Aylward

Gladys knew that God was calling her to China.

"You would not make a good missionary!" some people said. "You are not even trained for anything useful, like teaching or nursing."

Living in England fifty years ago, the family was quite poor. Gladys's father was a postman and did not earn very much.

"How can I ever get enough money to go to China?" thought Gladys.

When Gladys was old enough she was able to get a job herself. She saved hard and worked over time. Finally she had enough money for a one-way ticket to China. In fact she had just two pounds over. The ticket to China was not a plane ticket or a boat ticket, but a train ticket. She would have to go overland through Holland, Germany and Russia.

Gladys had heard of an old lady who was working as a missionary in China. Her name was Mrs. Lawson. Gladys decided that she would go to help Mrs. Lawson. As Gladys boarded the train with her two suit cases and just two pounds, she felt excited. The train set off. Gladys had been warned about the war between Russia and China.

"You may not get through, you know," people said. But Gladys didn't worry. God would take care of her.

While travelling through Russia, the train stopped suddenly. It could go no further because the line was blocked due to the war. Gladys got off the train and started walking. After walking many miles carrying her luggage, she was able to catch another train to a busy Russian port. From here she caught a boat to Japan, then another to China. Once she was in China, she had to find Mrs. Lawson. It was another long journey to the inland of China, through wild mountains, on the back of a mule.

Gladys proved to be a great help to Mrs. Lawson, who ran an inn for travellers. As travellers stopped to rest, and water their mules, she would share the love of Jesus with them. She had employed a good Chinese cook, so the inn had quite a reputation for its good food. Each night, before the travellers went to bed, Mrs. Lawson would tell stories from the Bible. Gladys listened carefully to the Chinese language and was soon making good progress. One day, Mrs. Lawson, who was now a very old lady, died suddenly. Now it was up to Gladys to carry on the work.

Gladys soon became popular with the Mandarin. (The Mandarin was like a prime minister.) He asked Gladys to help him stamp out the old practice of foot-binding. For many centuries, the feet of baby girls had been tightly bandaged so that the feet would not grow to their proper size. Small feet were thought to be more attractive. The Mandarin asked Gladys to be the official inspector of feet! This meant visiting the villages and reporting any cases of foot-binding.

It was on one of these visits to the villages that Gladys met a woman who could not afford to look after her child. Gladys took the little girl home and cared for the child herself. Soon

Gladys found that there were many children who had no homes because their parents could not afford to look after them. Soon she had many children to care for.

A war had broken out between China and Japan. It took some time for the fighting to reach the inland, but finally the bomber planes encircled the city where Gladys lived. They came again, and this time dropped bombs on the city. Gladys and her children were not harmed, but she knew that she must flee from the city to a village far away, where she knew of some Christians who could help her look after the children. By this time Gladys was looking after nearly one hundred children.

It was soon obvious that even the village would not be safe. She knew of a centre for homeless children far away beyond the mountains in Siam. She must take them there. They would have to go on foot. The Mandarin, who had now become a Christian, gave Gladys some sacks of rice and two men to carry them. It normally took four days to cross the mountains, but because of the Japanese soldiers, they had to avoid the main road. They would have to pass through difficult terrain.

"It will take you at least twelve days," said the Mandarin.

The children walked and walked, without complaining for the first few days, but then they became tired. The sacks of rice started to get low. Every day Gladys read to the children from the Bible, and they asked God to help them. As the last of their food was used, Gladys knew that God would provide.

"We're hungry!" said the little ones.

"Look, some soldiers!" said Gladys. No, not Japanese soldiers. They were Chinese soldiers who gave the children some food. Soon this food was gone, and they were hungry again. God provided again as they came upon a mountain village.

"Please give us some food," begged Gladys. "The children are hungry."
The villagers gladly supplied them with food.

At last they reached the Great Yellow River. This was the final obstacle before reaching safety. When they reached the river bank they realized that there was no ferry to take them across. The Japanese soldiers had stopped all boats. If they waited here too long they would be discovered. They waited and prayed. Then a Chinese soldier came along.

"What are you doing here with all these children?" he asked.
Gladys explained.

The soldier knew about a secret boat, hidden amongst the reeds on the other bank. The soldier gave a whistle. Quickly and quietly the boat made its way across the river. It collected the children and ferried them to the other side. Once again the Lord had provided for them, and protected them. By the time they reached the town where the children would be cared for, Gladys was very ill. In this town there was a Christian mission hospital where Gladys stayed until she was well again.

It was only because of the Gladys's great trust in a great God, that she was able to take one hundred children on such a dangerous journey, and every one of them was kept safe.

Art/Craft

Make a 'God is Provider' group collage. Cut food pictures from magazines. Arrange them in a design.

Cooking Activity - Make some 'manna toast' (toast with different toppings.)

God is Provider 5.2

Subtheme

God is a faithful provider

Focus

Our trust in a faithful God

Bible references

Exodus 17 Water from a rock.

Psalm 119:86 All God's commands can be trusted.

Psalm 56:3 I put my trust in You.

Psalm 20:7 We trust in the power of the Lord our God. (GNB)

Songs

The Journey (*Sing A Joyful Song*)

The Dancing Song (*Sing A Joyful Song*)

Let's Celebrate (*Sing A Joyful Song*)

Thank You for All the Good Things (*Couldn't Be Finer*)

Thank You Lord for this Fine Day (*Couldn't Be Finer*)

Revision

How did God miraculously provide for the people of Israel as they travelled through the desert?

What did the people learn about God as a result of these miracles?

Would you expect the people to have trusted God the next time they found themselves with no food or water?

Do people always trust God even though they know He is faithful?

What does God say about these things in Matthew 6:25-27?

Activity: Trust exercise

Prepare a selection of foods in glass containers.

EXAMPLE

1st glass: lemon juice

2nd glass: breakfast cereal

3rd glass: milk

4th glass: spicy sauce

5th glass: salt water

Establish which foods are liked/disliked. Ask one child to volunteer to be the taster. The taster must wear a blind-fold, and TRUST someone to give him a sample of a pleasant tasting food.

After the exercise, ask the taster whether he/she found it easy to trust.

Why is trusting not always easy?

Can we trust God?

Story 1: Water from a rock

God's people, the Israelites were travelling from Egypt to a special land which God had promised to them. Much of the country over which they travelled was desert. Occasionally they would come across some water. They would drink as much as they needed, and then replenish the supply of fresh water in their skin bags. This time, however, they had run out of water, and there was no water in sight. The people were thirsty. They were also afraid of

dying there in the desert. They had forgotten about the time God had provided water for them just three days after crossing the Red Sea. They started complaining to Moses.

"Have we come out here in the desert to die?" he asked.

Moses prayed to God. God spoke back to Moses:

"Take your stick and go to the big rock at Mount Sinai. Hit the rock with a stick and water will come out of it. Then the people and the animals will be able to drink."

Moses did as God had said. Water gushed out of the rock and all the people drank as much as they needed.

When we trust God He always gives us what we need. He never lets us down. God is faithful.

Story 2: Money from a Fish

The twelve disciples travelled around the country with Jesus. They watched Him heal people. They listened to Him tell stories about God's kingdom. Jesus and the disciples needed many things, but Jesus always provided.

The disciples could have worried about food and clothes. After all, they didn't work as fishermen or tax-collectors any more. They didn't go to work each day to earn money. But Jesus told them not to worry. "Your Heavenly Father knows what you need," he said.

Jesus always made sure the disciples had the things they needed. He even provided money to pay their taxes. This was the money everyone had to pay to the king.

One day, a tax-collector came to Peter. The tax-collector said, "Does Jesus pay taxes?"

Peter answered, "Yes, Jesus pays taxes."

Peter went to Jesus to ask about the tax money, but Jesus already knew what Peter was going to ask.

"Go down to the lake," said Jesus, "and do some fishing. Open the mouth of the first fish you catch. Inside the mouth of the fish you will find a coin. Take that coin and give it to the tax-collector. That will be enough to pay taxes for all of us."

Peter did as Jesus said, and sure enough, Peter pulled up a fish with a coin in its mouth. God had once again provided the money that they needed.

Brainstorm

When we find it difficult to trust God, we can remember how faithful He has been in the past.

Think of as many Bible stories as possible which remind us of God's faithfulness.

Think of times when God has been faithful to you or your family in the past.

Crossword

Across

1. God always gives us the things we need. He is _____.
2. Water came out of the _____.
3. The Israelites found it difficult to _____ God, even though they had seen Him do great miracles before.
4. Jesus said, "Do not worry about food or _____."

Down

1. Jesus said, "Pull up the _____ fish you catch and open its mouth."
2. The tax-collector asked _____ whether Jesus paid taxes.
3. Moses hit the rock with a _____.
4. These two stories show us that God always _____ for His children.

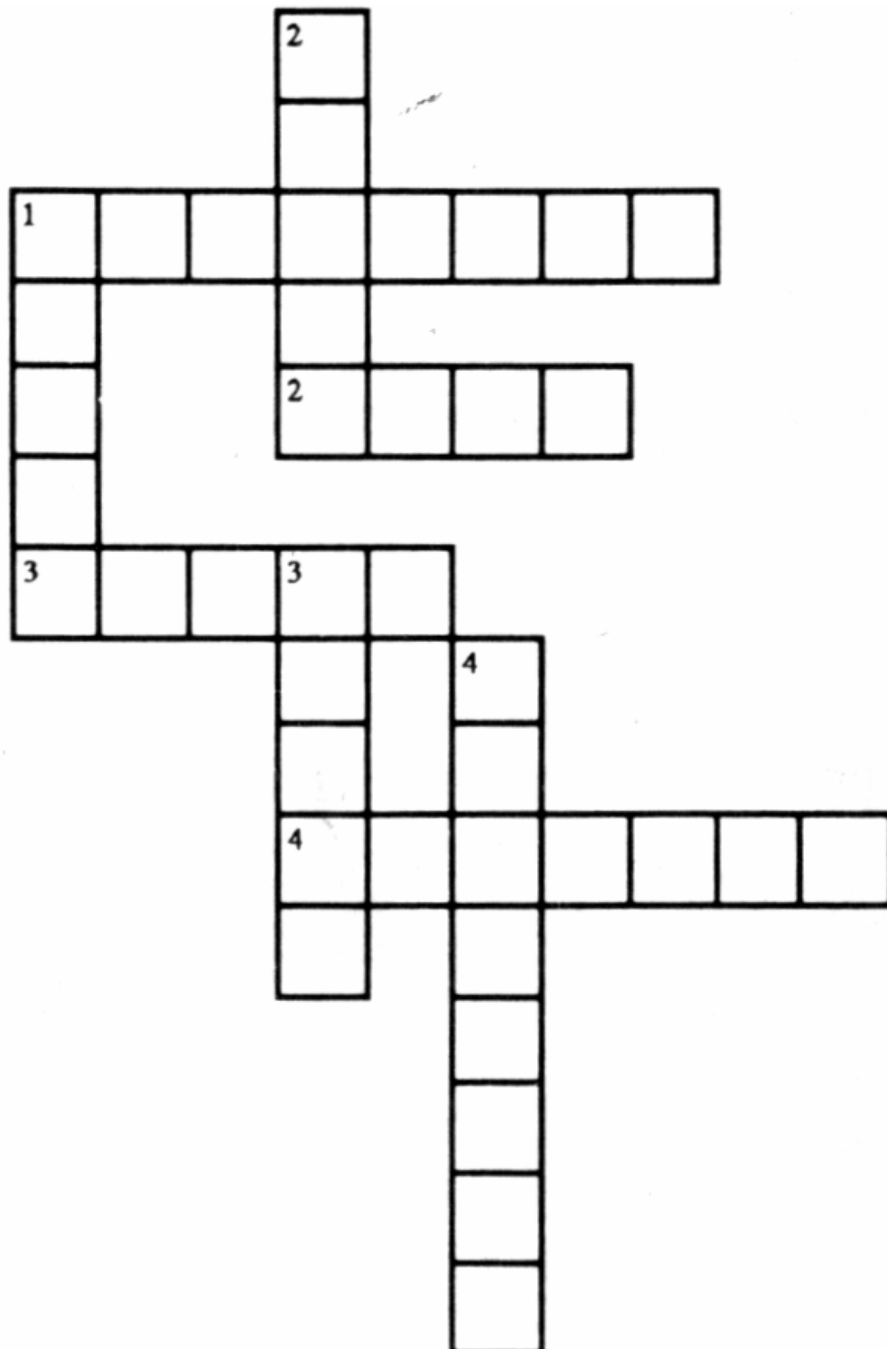

God is Peace

Level 5 (age 9)

Subtheme

Trouble outside: peace inside



*We have peace with God through our Lord Jesus Christ.
Romans 5:1*

Integrated Topics for Christian Education

- Discovering elements of peace and harmony in art and music
- Peaceful experiences through the environment; bush walks/nature walks
- Comparing rural and city life

Other

- security through homes and families
- peaceful play
- trust, (inner peace)
- dealing with fears, (obstacles to inner peace)
- national and international peace
- biographies of peacemakers and those who have struggled for peace
- obstacles or barriers to peace: hatred, jealousy and racial prejudice

Character Development

- contentment
- being a peace-maker

Christian Life

- experiencing inner peace
- feeling safe and secure in God's care

God is Peace 5.1

Subtheme

Trouble outside, peace inside

Focus

Finding comfort through the Holy Spirit in times of trouble

Bible references

Matthew 7:24-26 The house on the rock.

Job: Job trusted God, despite many troubles.

John 14:1-3,18,25-27 Jesus promised inner peace to His disciples, and the comfort of the Holy Spirit.

2 Corinthians 1:3-4 God comforts us in times of trouble.

John 16:33 In the world we have tribulation but in Christ we have peace.

Matthew 11:28 Come to me all of you who are tired from carrying heavy loads, and I will give you rest. (GNB)

Songs

God is my Peace (*All Creation sings*)

The House on the Rock (*All Creation sings*)

I Don't Have to Worry (*Sing A Joyful Song*)

Do Not Worry (*Couldn't Be Finer*)

Introduction

Look at two contrasting examples of art: one which gives a peaceful feeling, and one which gives the opposite feeling.

Story 1: The Two Artists

Once upon a time there were two artists. Each artist was asked to paint a picture that would best depict the idea of peace.

One artist painted a crystal clear lake in the mountains. There was not a breath of wind, and not a ripple on the lake. The lake, like a mirror, reflected the image of the surrounding trees and mountains.

The second artist painted a picture of a roaring waterfall. Hanging over the waterfall was a great tree branch. Hidden away in a secure part of the limb was a little bird's nest. Inside the nest was a tiny bird, sitting peacefully as the water rushed and swirled below her and the water sprayed around her. Amidst the tremendous roar of the waterfall the little bird sat as if she had not a worry in the world. Her nest was snug and warm, nestled in the strong branch. She knew she was safe.

Discussion

1. Which picture do you think gave the best idea of peace?
2. How can the second painting be similar to a Christian feeling safe and secure on God's care?
3. What kind of troubles can we have?
4. Does God promise that a Christian will be free from all troubles? Read John 16:33
5. God does promise that when we do have troubles, He can give us peace inside. Read Matthew 11:28

6. Is there a similarity between the story of the house on the rock, and the second painting? Read Matthew 7:24-26

Story 2: Troubled Times for Jesus' Friends

Jesus called His disciples together. He tried to explain the hard times ahead for them all. Jesus would have to die, but on the third day He would come alive again.

"No!" said His friends. "You do not have to die!" They could not understand it. The thought of losing their best friend was too much for them to bear.

Jesus understood how they felt. He knew that it was going to be hard for them. He also knew that God had a special surprise in store for them .

"Don't let your hearts be troubled," said Jesus. "I am going to leave you, but I won't leave you alone like orphans,"

Jesus explained that He was going to send the Holy Spirit who would help them. The Holy Spirit would help them and give them peace inside. Read John 14:25-27

Discussion

1. How did Jesus know He was going to die?
2. Why would it be hard for the friends of Jesus?
3. Read John 14:25-26. Who did Jesus send as a helper in troubled times?
4. What does Jesus tell us in John 14:27?
5. What should we do when we feel troubled or afraid?
6. Read: Luke 11:13b and 2 Corinthians 1:3-4

Activity: Peaceful musical sounds?

Experiment with musical instruments, e.g. triangles, shakers, rhythm sticks. They can be home made, e.g. rubber bands, shakers, water in glasses. Decide which combination of sounds make the most peaceful and harmonious music. Which ones make discords?

Now use percussion to accompany a song in a peaceful way. Choose gentle sounding instruments for peaceful music.

Contrast with loud instruments for upbeat songs. Discuss the difference.

Art

Draw a peaceful picture.

God is Peace 5.2

Subtheme

Trouble outside: peace inside

Focus

The peace which comes from trusting God

Bible references

Mark 4:35-41 Jesus calmed the storm.

Daniel: Daniel's trust in God.

1 Samuel 17 David's trust in God

Galatians 5:22 Peace is a fruit of the Spirit.

Songs

God is my Peace (*All Creation Sings*)

Do Not Worry (*Couldn't Be Finer*)

I Don't Have to Worry (*Sing A Joyful Song*)

Introduction

Decide on a definition of peace.

For a Christian, peace is a calm feeling in the inside, even when there is trouble on the outside.

How do we get that peace?

We can have peace by asking the Holy Spirit to help us, and by learning to trust God at all times.

Trust Game

How well do you trust these? (Give a score between 1 and 5, according to how well you trust each one.) When finished, share your answers.

- a) Dad's cooking
- b) A Jumbo jet
- c) Your chair
- d) A family car
- e) Advertisements
- f) A dentist
- g) A doctor
- h) A chair lift

Discussion

What's the difference between trusting these things/people, and trusting God?

Brainstorm

Try to think of different people in the Bible who trusted God in times of difficulty.

Write up ideas on a large piece of paper.

Story 2: Houdini

Houdini was one of history's most famous performer.

"How does he do it?" people would wonder.

One of his most famous acts involved an escape from a sealed box, submerged under water. With his great strength he could break himself free and swim to the surface. His strength was not only in his muscles, but also in his lungs. He could hold his breath under water for an amazing time.

Houdini's success was due to his great strength and superb muscle control. However, there was something else. Houdini had no fear.

Discussion

This story about Houdini teaches us something about trust. Houdini had no fear because he knew that his great strength and muscle control could enable to do amazing things. He TRUSTED in his own great ability. This is why he had no fear.

Fortunately for us, we do not have to trust in our own strength, but we can trust in God who is a mighty God. If we trust in God's greatness we will have no fear.

Story 2: Blonden, the Tightrope Walker

There is a well-known story of a famous tight rope walker called Blonden, who stretched a tight-rope across the great Niagra Falls.

With a crowd of spectators watching in amazement, he proceeded to walk across the tight-rope to the other side. One slip would have sent him falling to his death below.

The crowd cheered as Blonden reached the other side safely. Then, much to everyone's surprise, he walked the rope again, this time, wheeling a wheel-barrow before him. Once again the crowd cheered as he reached the other side safely.

'What will he do next?' the crowd wondered. Then, Blonden stood and called out to the spectators, "Who would be willing to sit in the wheel-barrow and be taken across to the other side?"

There were no volunteers.

Discussion

How do we know the crowd thought Blonden was a great tight-rope walker?

Why didn't anyone trust Blonden's ability to wheel them across safely?

Would you have climbed into the wheel barrow?

This story shows us that even the greatest human skill in the world cannot always be trusted. However, there is someone who can always be trusted. That's God.

We can trust God because He has power and ability greater than any human. When we feel afraid, we should remember that He will never let us down. When we TRUST Him we have peace inside.

Story 3: Jesus Calms the Storm

Read the story from Mark 4:35-41.

Discussion

Do you think the disciples should have had more trust?

Sometimes we don't trust God when we have difficulties, but God wants us to remember that He is TRUSTWORTHY.

Just as Jesus helped the disciples when they were afraid, He can help us too.

Art/Craft

Draw a cartoon strip of the tight-rope walker. Include captions to show what people are saying.